



LX449

Voltage regulator for generators

Instruction Manual V2.4

Product version V1.5.8.2



EMRI ELECTRONICS
POWER IN CONTROL



WARNINGS AND COMMISSIONING INFORMATION



HAZARDOUS VOLTAGES.



DO NOT OPERATE WHEN NOT FAMILIAR WITH GENERATORS.

- **Check the isolation of the generator windings before installation.**
Poor isolation will cause damage to the AVR and dangerous situations for persons.
- The system should not be installed, operated, serviced or modified except by qualified personnel who understand the danger of electric shock hazards and have read and understood the user instructions.
- Never work on a LIVE generator. Unless there is another person present who can switch off the power supply or stop the engine.
- Dangerous voltages are present at the voltage regulator board. Accidental contact with live conductors could result in serious electrical shock or electrocution.
- Disconnect the power source before making repairs, connecting test instruments, or removing or making connections to the voltage regulator or generator.
- Defects in the generator or AVR may cause consequential loss. Precautions must be taken to prevent this from occurring.
- The unit should be installed with respect to the environmental specifications as well as the rules mentioned in the General installation information.
- For safety reasons the voltage level potentiometers are best turned completely counter clockwise in order to start at the lowest possible voltage.
- Never change the rotary switch or dipswitch settings during operation.
- Never apply supply voltage when generator is not running, unless exciter field is disconnected.

REVISION HISTORY

Product	Version			Change
	Hardware	Software	Manual	
For info about older revisions contact your supplier.				
V1.4.0.0	1.3	1.4	1.4.4/1.4.5	<i>Improved HW filtering and CAN readout.</i>
V1.4.1.0	1.4	1.4.1	1.4.6	<i>Added inverse mode, external cosphi setpoint added.</i>
V1.4.3.0	1.4	1.4.3	1.4.6	<i>Improved voltage match function. Added more sw advanced options.</i>
V1.4.4.0	1.5.0	1.4.3	1.4.6	<i>JTAG connector changed. Minor pcb changes.</i>
V1.5.0.0	1.6.0	1.6.0	1.5	<i>Minor software changes Minor hardware changes</i>
V1.5.3.0	1.6.0	1.7.0	2.0	<i>Added Capacitive limit during cosphi control. Improved flash acces.</i>
V1.5.3.1	1.6.0	1.7.1	2.0.1	<i>Bugfix negative AVR temperature.</i>
V1.5.7.0	1.6.2	1.7.2	2.2	<i>New sensing transformers. Calibration of sensing transformers.</i>
V1.5.8.0	1.6.3	1.7.2	2.3	<i>Minor pcb change.</i>
V1.5.8.2	1.6.3	1.7.3	2.4	<i>Voltage mode LVRT Capability (LVRT In pf-mode is already implemented)</i>
The table provides a historical summary of the changes made to the AVR. Revisions are listed in chronological order.				

The manual does not cover all technical details of the product. Specifications may be modified by the manufacturer without notice. For further information, the manufacturer should be contacted.

TABLE OF CONTENTS

General description	4
Absolute maximum ratings	5
Protections	6
CAN Interface	6
Modes of control I	7
- <i>Buildup (PMG)</i>	- <i>Buildup (Self excite)</i>
- <i>Constant voltage control</i>	- <i>Volt per Hertz control</i>
- <i>0-100% Voltage control</i>	- <i>0-100% Current control</i>
Modes of control II	8
- <i>Setpoint control</i>	- <i>Remote control</i>
- <i>Stability control</i>	- <i>Droop</i>
- <i>Current Limit</i>	- <i>Motor start</i>
Modes of control III	9
- <i>Voltage matching</i>	- <i>Cosphi setpoint</i>
- <i>VPH mode</i>	- <i>Min. excitation at Cosphi</i>
- <i>Cosphi setpoint with Cap. limit</i>	- <i>Cap. Limit at Cosphi</i>
Quick reference I & II	10
- <i>Hardware connections</i>	- <i>Factory settings</i>
- <i>Rotary switches</i>	- <i>Dipswitches</i>
- <i>Potentiometers</i>	- <i>Status LED</i>
Advanced settings I & II	12
- <i>Programming advanced settings with rotary switches (AVR)</i>	
Wiring diagrams	14
General installation information	19
Contact	20

GENERAL DESCRIPTION

The AVR is designed as a replacement for the R449, providing optimal flexibility and configurability as is reflected by the additional capabilities of the AVR.

Nevertheless installation, maintenance and adjustment don't require special application software.

The AVR is protected from the environment by a PUR coating.

Mode of control	R449	LX449
Volt per Hertz control		✓
Constant voltage control	✓	✓
Power factor control (PFC)		✓
0-100% generator current control		✓
0-100% generator voltage control		✓
Quadrature voltage droop for parallel operation	✓	✓
Current control (Current limiting / Limited motor start)		✓
Protection		
Generator phase loss & phase sequence		✓
AVR over temperature		✓
Generator over temperature		✓
Generator over voltage	✓	✓
Generator over current	✓	✓
Generator over excitation	✓	✓
Loss of excitation during PFC		✓
Loss of current sensing during PFC		✓
User adjustable underspeed knee	✓	✓
User adjustable over excitation current		✓
User adjustable generator current limit		✓
Communication		
AVR Status LED	✓	✓
AVR Status contact		✓
CAN bus		✓

Options		Terminals
DROOPCAT	Required for current limiting	S1 – S2
LX_VMA	Required for voltage matching	A1 – A2
LX_TRIP CB + COIL	Over voltage trip protection	B0 – B1
3F-Filter	For filtering the generator sensing voltage	U – V - W
AVR Assistant	Handheld programming and monitor device	CAN
DFD7.5	Diode failure detector	Separate unit
RunDect	Motor stall protection & End of run-up detection	Separate unit

Smart grid:

The automatic voltage regulator is compliant for applications in generators - power generation sets which should meet:

Smart grid BDEW Technische Richtlinie „Erzeugungsanlagen am Mittelspannungsnetz“.
 Dynamic grid support.
 Low voltage ride through (LVRT).
 Under voltage ride through (UVRT).
 High voltage ride through (HVRT).
 Contribution to short-circuit.
 Reactive power control strategies ($\cos \varphi$).

VDE-AR-N-4100:2019-04

VDE-AR-N-4105:2019-04

ABSOLUTE MAXIMUM RATING

Symbol	Parameter	Condition	Min.	Max.	Unit
U, V, W	Voltage sensing input ⁽⁶⁾	50Hz, continuous	-	450	V _{AC}
		50Hz, Intermitted < 30s.	-	480	V _{AC}
		60Hz, continuous	-	500	V _{AC}
		60Hz, Intermitted < 30s.	-	520	V _{AC}
E-,E+	AVR field current	Intermitted < 10s. ⁽¹⁾	-	15	A _{DC}
		Continuous @70°C	-	10	A _{DC}
	Field resistance	Continuous @50°C	-	13	A _{DC}
	Field resistance I1(+), K1(-)	@ 70V _{AC} supply ^{(4) (5)}	5	-	Ω
		@ 170V _{AC} supply	12	-	Ω
X1-X2	Supply input	X1, X2, Z1, Z2	15	300	V _{AC}
Z1-Z2		DC or 25 - 400Hz (No DC on X1)	15	135	V _{DC}
X1-X2	Input for self excitation	Input SE1-SE2 must be closed	5	-	V _{AC}
A1, A2	Accessories input ⁽²⁾	A1(+), A2(-) ⁽³⁾	-13	+13	V _{DC}
S1, S2 (U)	Droop, PFC, Limit CT	Isolated CT > 2VA, Intermitted < 30s.	-	3	A _{AC}
T _{AMB}	Operating temperature	95% RHD non condensing ⁽¹⁾	-30	+70	°C
T _{STG}	Storage temperature	95% RHD non condensing	-30	+85	°C
	Static control accuracy			1	%

⁽¹⁾ Always mount with heatsink fins aligned vertically and allow for sufficient airflow.

⁽²⁾ Isolated input.

⁽³⁾ Input resistance is 1KΩ.

⁽⁴⁾ See table below for safe operation area of the AVR.

⁽⁵⁾ See formula for calculating minimum field resistance.

⁽⁶⁾ Depending on voltage selection



$$\text{Field resistance } (\Omega) \geq \frac{\text{Supply input} \times \sqrt{2} \text{ (V}_{\text{DC}})}{20}$$



Stresses above “Absolute Maximum Ratings” may cause permanent damage to the device. This is a stress rating only, the functional operation of the device or any other conditions indicated in the “operation area” of this specification is not implied. Exposure to maximum rating conditions for extended periods may affect device reliability and lifetime.

Operating Area

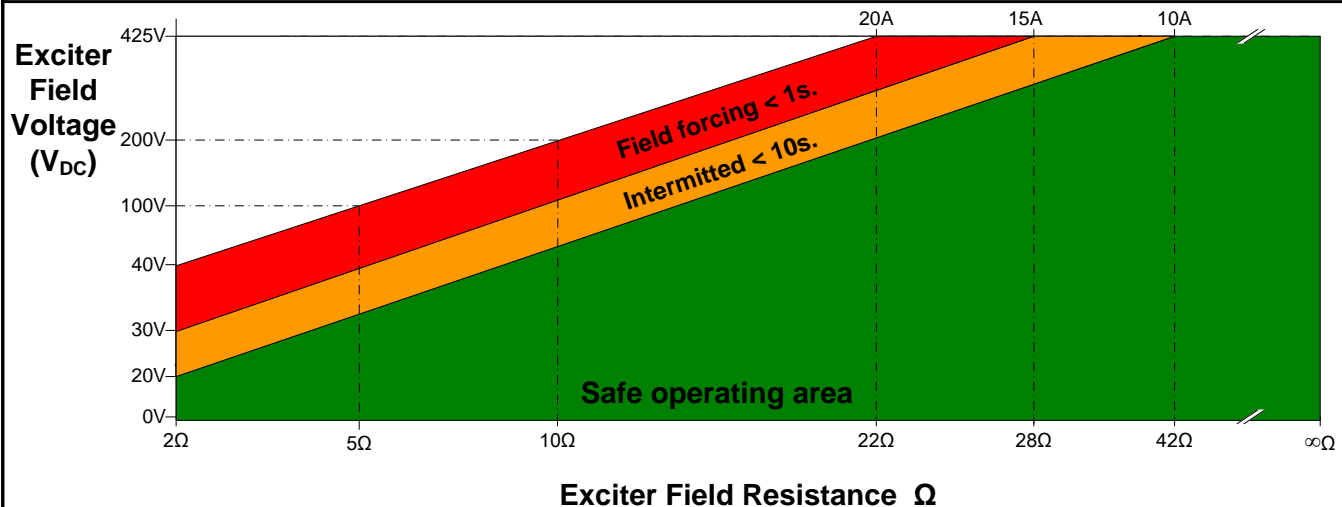

Exciter Field Voltage = Supply input x $\sqrt{2}$ (V_{DC})

PROTECTIONS

When a fault condition is active for more than time **T1**, the status contact deactivates. When a fault condition is active for more than time **T2**, the fault is indicated by the status led with **(N)umber of red blinks**. When protection "Excitation stop" is enabled, the AVR stops field excitation due to a fault. To **reset** the fault, open contact **AVR1-AVR2** for at least 10s, the AVR returns in idle mode.

In self excitation mode you must shut down the generator.

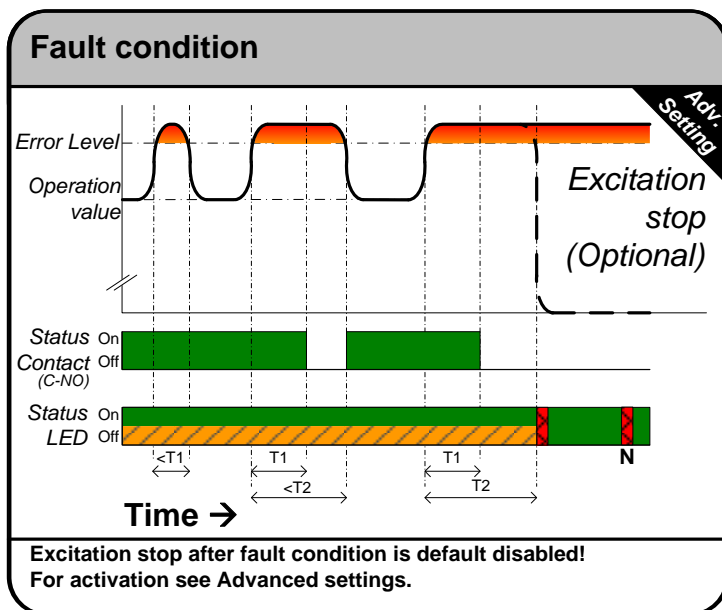

Protection	N	Fault Condition	T1	T2
Over voltage ⁽¹⁾	1	520V ⁽²⁾	1 s.	2 s.
Over current	2	200% of I-Lim	1 s.	2 s.
Over excitation	3	120% of Exc. Trip	0.3 s.	10.3 s.
AVR over temperature	4	85 °C	10 s.	20 s.
Generator over temperature	5	$R_{TH1-TH2} = < 1K7$ or $R_{TH1-TH2} = > 3K$	10 s.	15 s.
Phase loss & Phase sequence error	6	Phase loss or Phase sequence error	0.3 s.	5.3 s.
Loss of excitation during PFC	7	Excitation current < 100mA	5 s.	6 s.
Loss of current sensing during PFC	8	Current sensing < 2.5%	5 s.	6 s.

Excitation stop after fault condition is default disabled! For activation see Advanced settings.

⁽¹⁾ Trip coil (B0-B1) activated when AVR Excitation stop is enabled. ⁽²⁾ Sensing voltage U, V, W

CAN INTERFACE

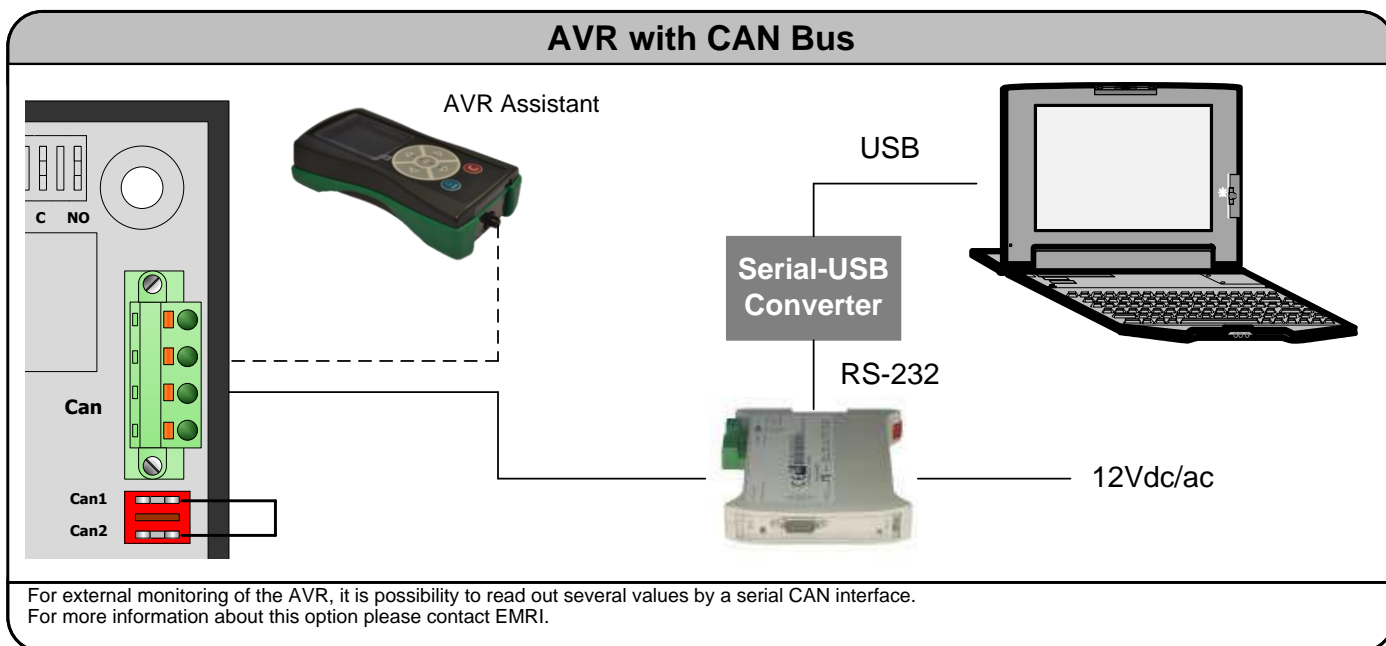

MODES OF CONTROL I

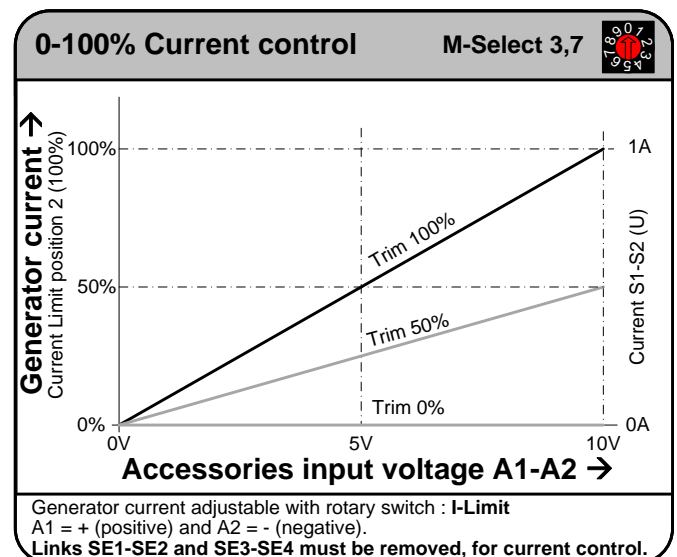
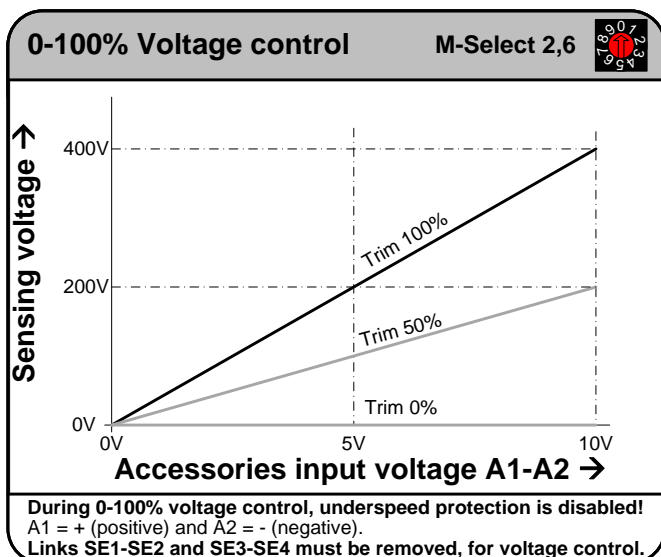
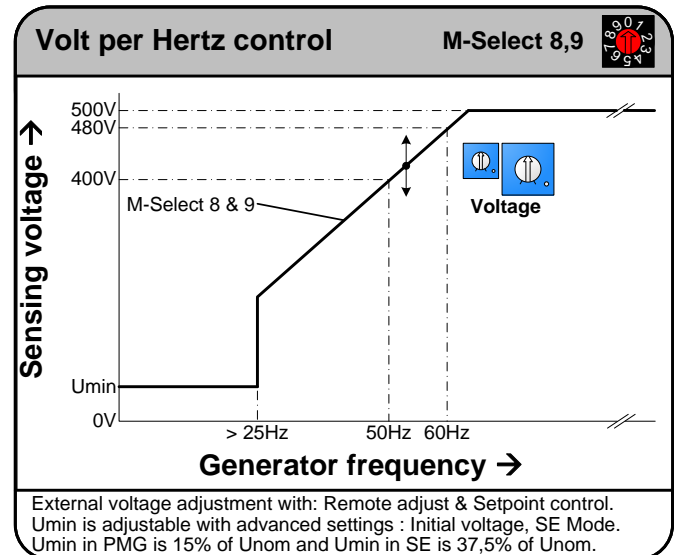
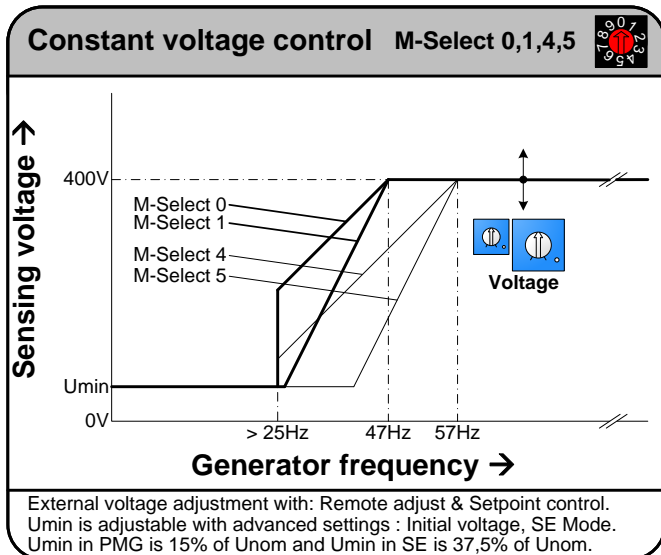
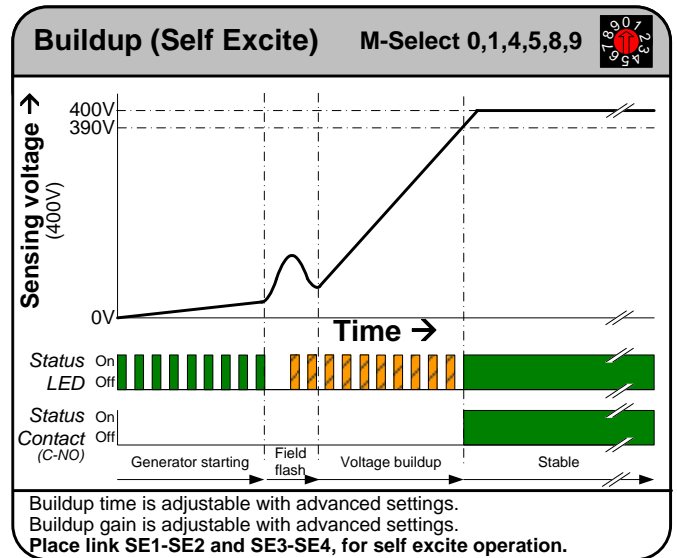
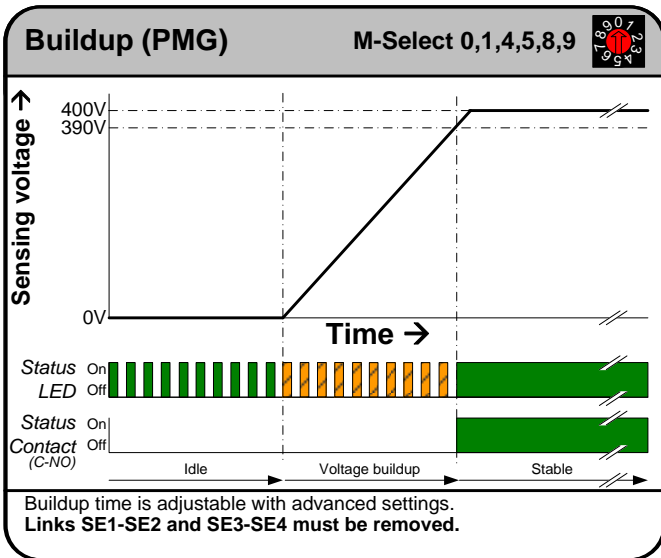

MODES OF CONTROL II

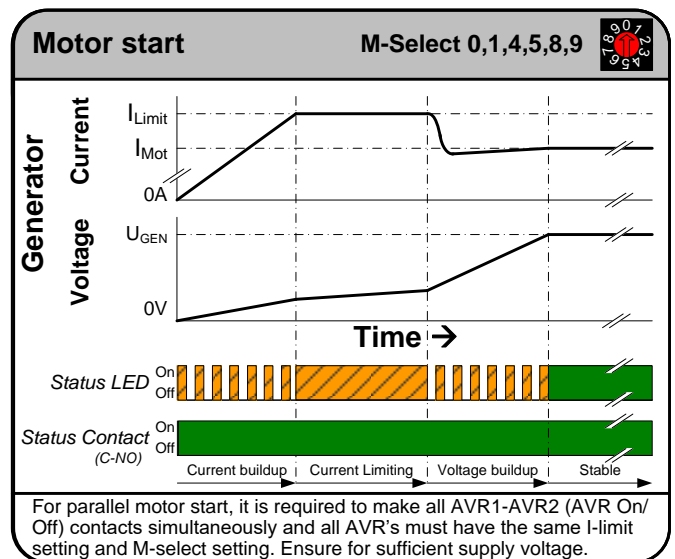
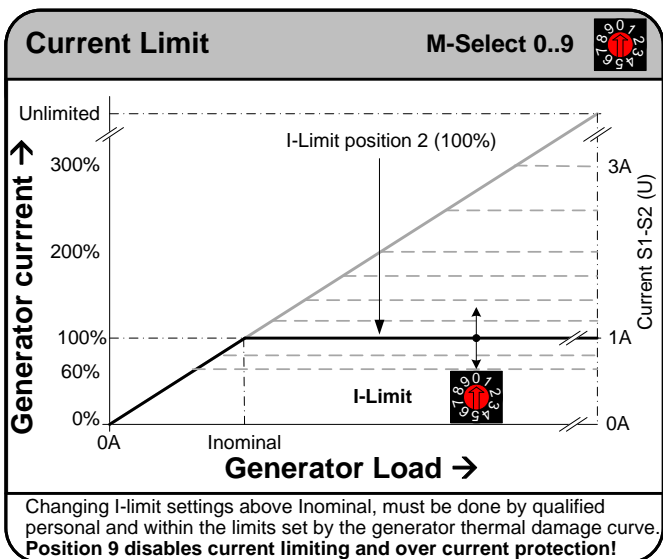
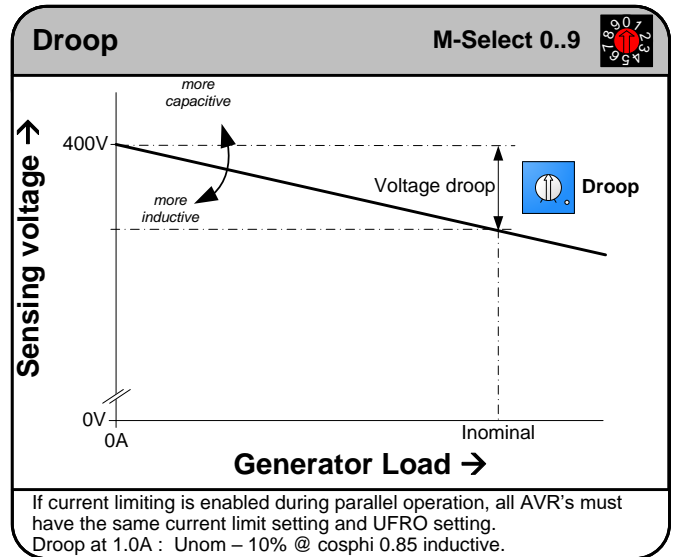
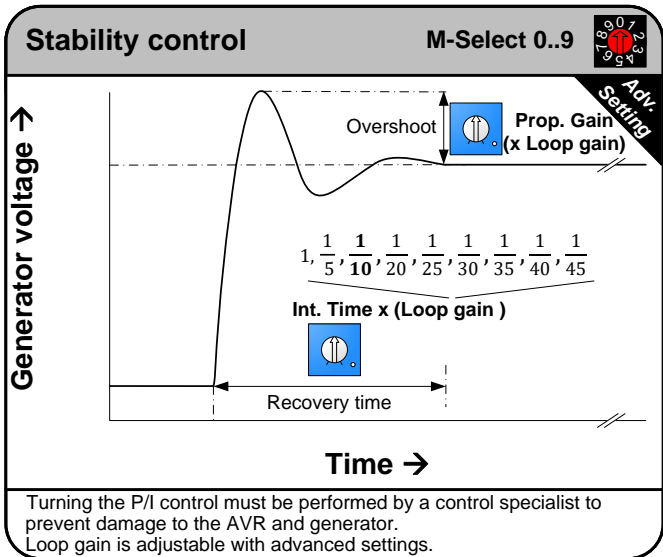
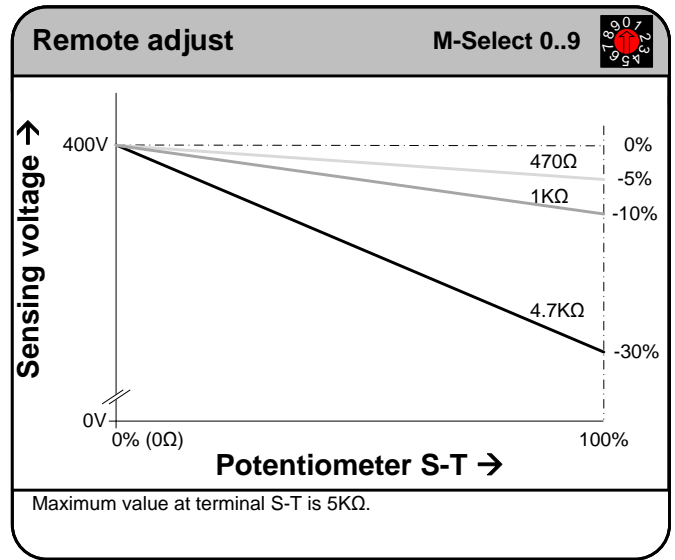
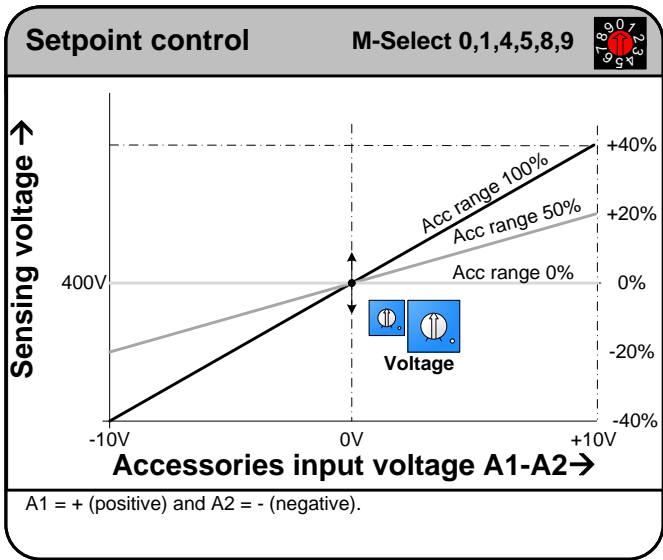

MODES OF CONTROL III

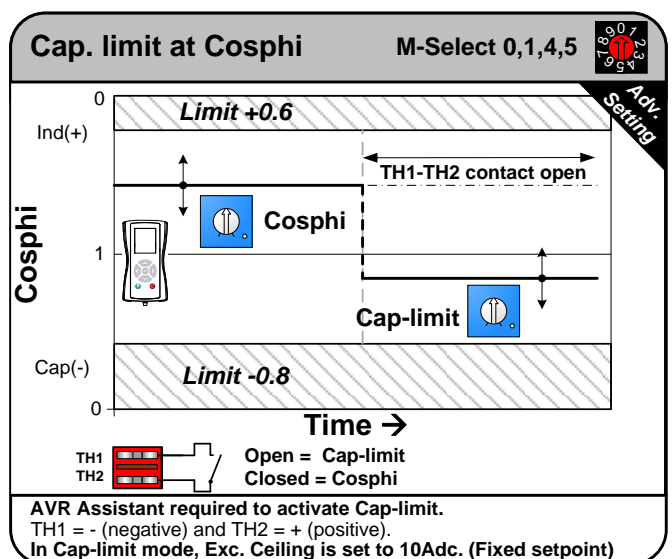
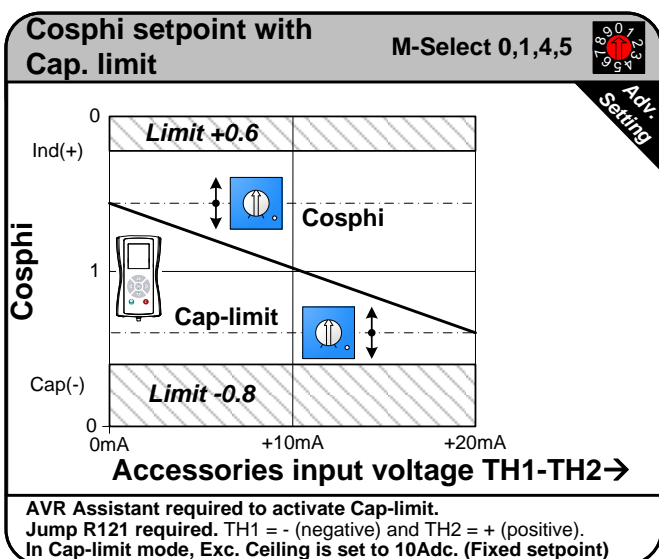
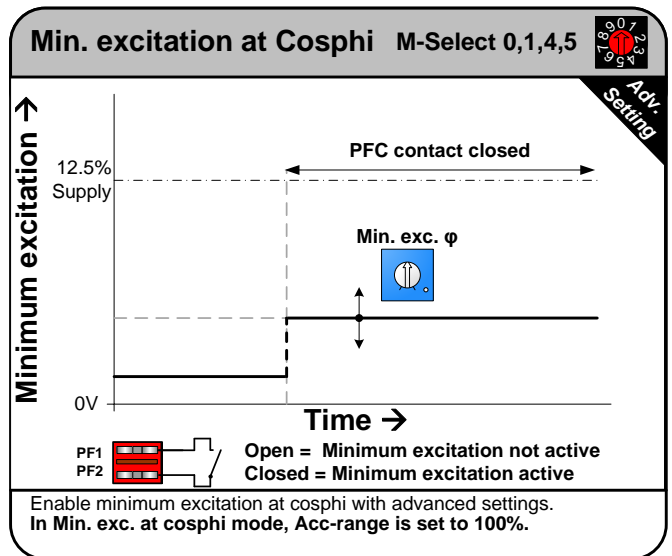
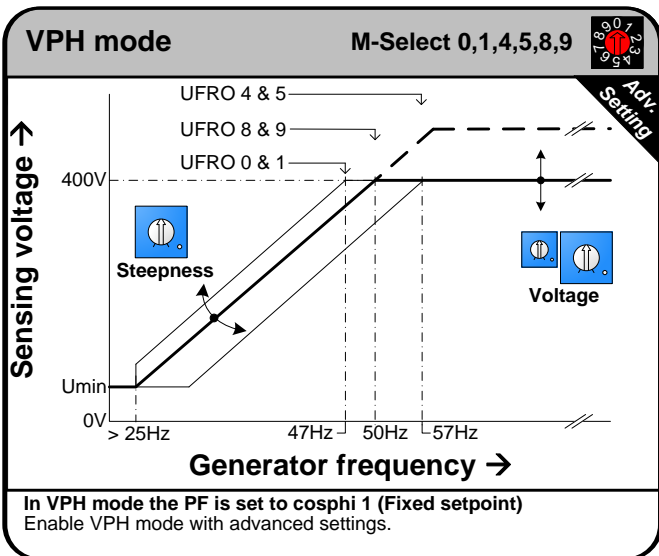
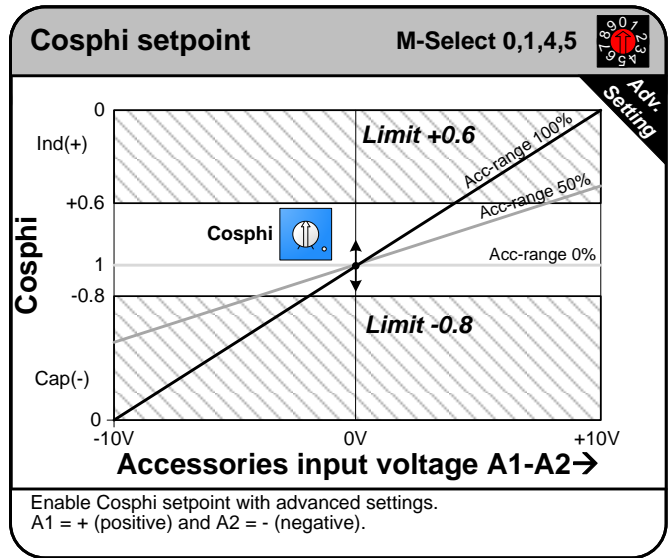
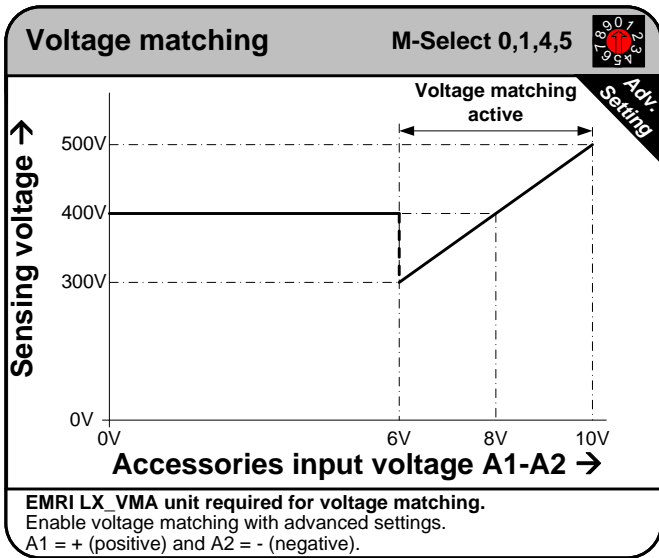

QUICK REFERENCE I

Voltage

Coarse

Fine

Stability

Prop. Gain
(x Loop gain)

Adv. Setting

Int. time
(x Loop gain)

Adv. Setting

Droop

I-Limit

0 = 60%	5 = 175%
1 = 80%	6 = 200%
2 = 100%	7 = 250%
3 = 125%	8 = 300%
4 = 150%	9 = Unlimited

Excitation ceiling / Cap. Limit

Normal mode

Exc. ceiling

Cap. Limit

Cap limit

Acc-range / Min. exc. φ

Normal mode

Acc-range
% of input A1-A2

Min. Exc. at Cosphi

Min. exc. φ
% of AVR supply

Cosphi / Steepness

Normal mode

Cosphi

VPH mode

Steepness

M-Select		Underspeed		
		TH1 – TH2		Slope (400V)
M-Select (Modes of control) <i>(Page 6,7,8,9)</i>		Linked	Open	
0	Constant voltage control	47 Hz	57Hz	8 V/Hz
1	Constant voltage control	47 Hz	57Hz	16 V/Hz
2	0-100% Voltage control with A1-A2	-	-	-
3	0-100% Current control with A1-A2	47 Hz	57Hz	8 V/Hz
4	Constant voltage control	57 Hz	47Hz	8 V/Hz
5	Constant voltage control	57 Hz	47Hz	16 V/Hz
6	0-100% Voltage control with A1-A2	-	-	-
7	0-100% Current control with A1-A2	57 Hz	47Hz	8 V/Hz
8	VPH (Volt per Hertz) control	-	-	8 V/Hz
9	VPH (Volt per Hertz) control	-	-	8 V/Hz

Factory settings

Control mode : Constant voltage
 Sensing : 400V
 Underspeed : 47Hz. (slope 8V/Hz.)
 Droop : 0V
 I-Limit : Unlimited (Pos. 9)
 Exc. Ceiling : 15A
 Prop. Gain : 50%
 Int. Time : 50%
 Acc-range : 0%
 Cosphi : 1

Link: SE1-SE2, SE3-SE4, S-T, AVR1-AVR2, TH1-TH2, CAN1-CAN2

Sensing

0..500Vac

U-V-W clockwise

Exciter field

0..10Adc
Max. rating: Intermittent 15A < 10s.
Max. rating: Field forcing 20A < 1s.

Check (Formula)

Internal (-) ER
 Exciter field E- E+
 +

Status Led

Green Blink	Idle
Orange Blink	Buildup
Green Continuous	Voltage control
Orange Continuous	Current control PF control
Red Continuous	Phase sequence Underspeed (<25Hz.)
Green with Red blink	Error: (n) number of red blinks
Error	
1	Over voltage
2	Over current
3	Over excitation
4	AVR over temperature
5	Generator over temperature
6	Phase loss or Phase sequence
7	Loss of excitation during PF control
8	Loss of current sensing during PF control

AVR supply

Max. rating: 15-300Vac / 15-135Vdc

Self Excite
SE1-SE2 Linked = Field flash on.
(AVR supply > 5Vac)
SE3-SE4 Linked = Min. setpoint.
(See advanced settings)

Minimum Rfield

Formula

Minimum field resistance

$$\text{Field resistance } (\Omega) \geq \frac{\text{Supply input } \times \sqrt{2} \text{ (V}_{bc})}{20}$$

QUICK REFERENCE II

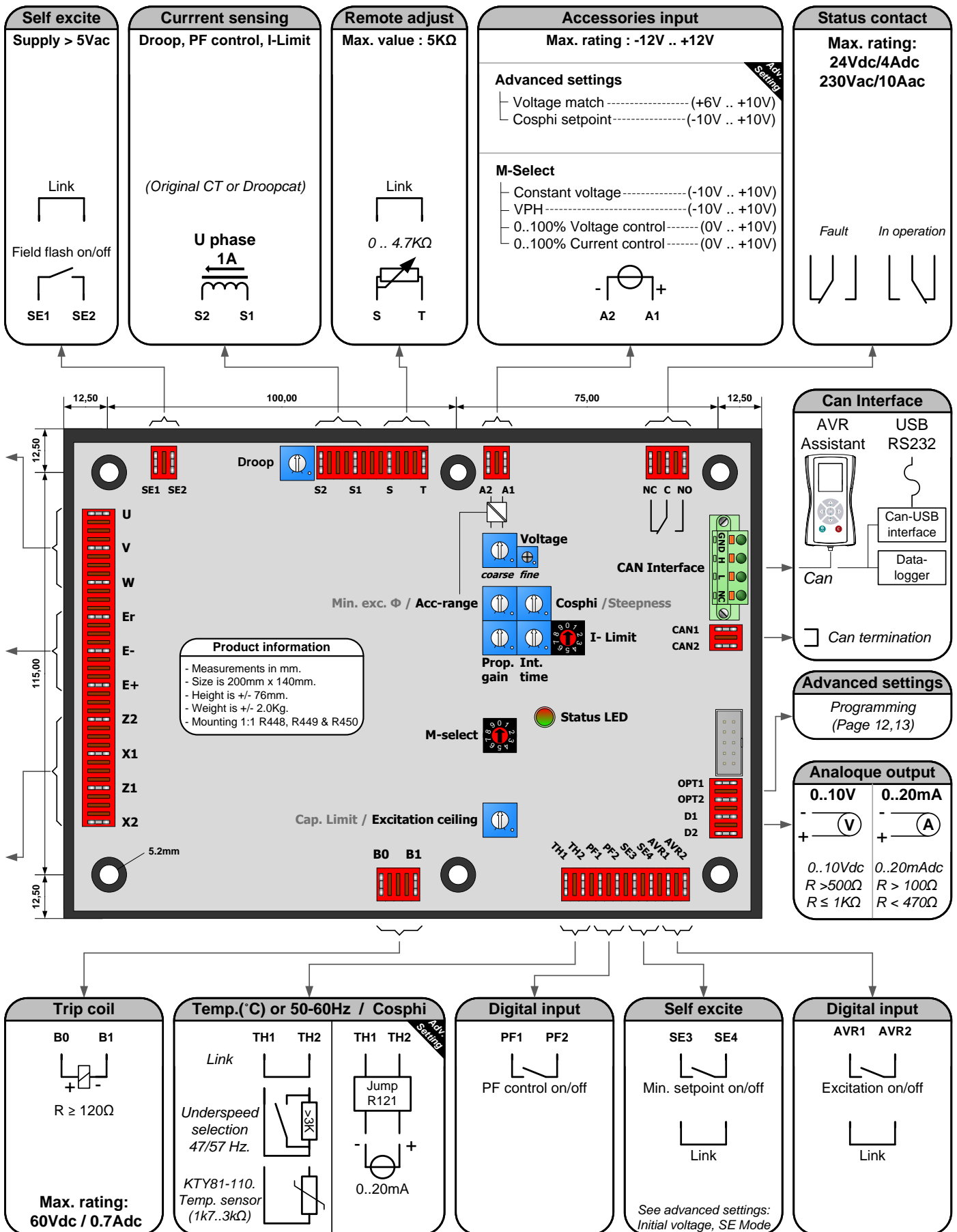

ADVANCED SETTINGS I

Advanced settings flowchart

Begin (Generator stopped !)

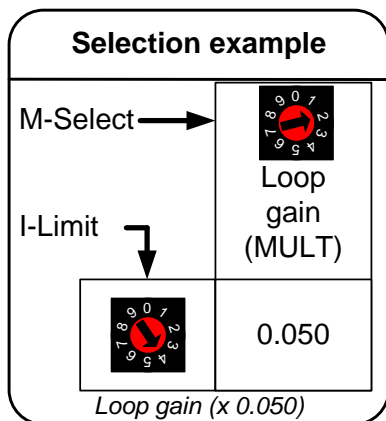
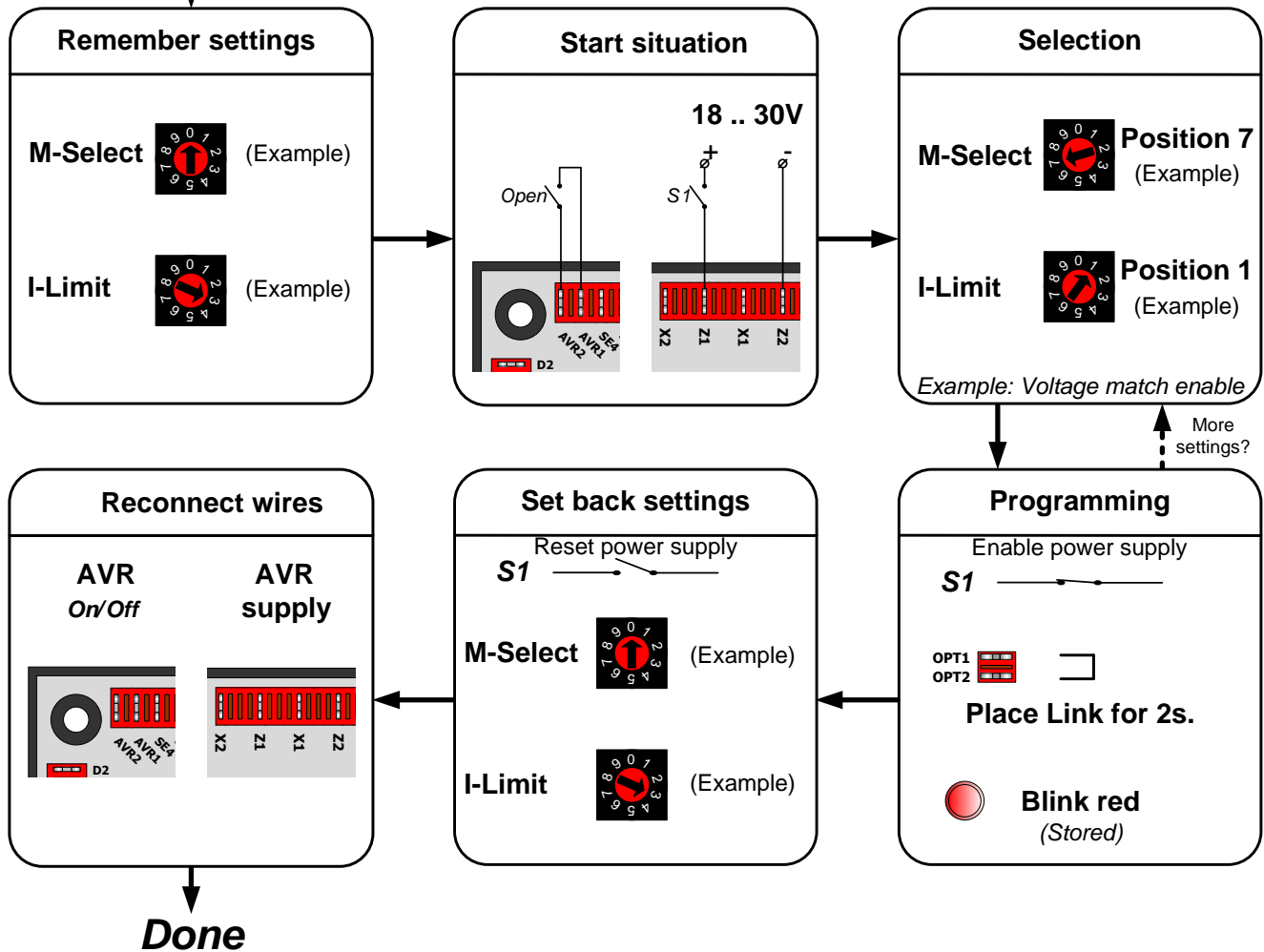



















Note

Change of setting only take effect after restart

Advanced settings can be adjusted according the flowchart.
Advanced settings are available with firmware version 1.2 and higher.

ADVANCED SETTINGS II

Advanced settings table									
<i>M-Select</i>									
	 Buildup gain (MULT)	 Loop gain (MULT)	 Initial voltage, SE Mode.	 Protections	 Buildup time @ startup	 Option output	 Accessory input modes	 Operation modes	
<i>I-Limit</i>									
	0.1 (slowest)	1.000 (fastest)	0%	Excitation loss disabled	1 sec.	Do not use *	Voltage match disabled	Inverted output disabled	
	0.2	0.200	10%	Excitation loss enabled	3 sec.		Voltage match ** enabled	Inverted output enabled	
	0.5	0.100	15%	Phase loss disabled	5 sec.		Cosphi setpoint disabled	Do not use *	
	1	0.066	22.5%	Phase loss enabled	7 sec.		Cosphi setpoint enabled		
	2	0.050	30%	Current loss disabled	10 sec.		Do not use *	VPH Mode disabled	
	4	0.040	37.5%	Current loss enabled	20 sec.			VPH Mode enabled	
	6	0.033	45%	Do not use *	30 sec.			Min. Exc. at Cosphi disabled	
	8	0.028	52.5%	Do not use *	45 sec.			Min. Exc. at Cosphi enabled	
	10	0.025	60%	Exc. stop after error disabled	60 sec.			Do not use *	
	14 (fastest)	0.022 (slowest)	67.5%	Exc. stop after error enabled	Cosphi setpoint 0..255 sec.				
Description	Extra multiplication factor for proportional gain. Only applied during field flash.	Extra multiplication factor for proportional gain.	Initial setpoint from which the AVR ramps up after field flash. Setpoint in % of Unom.	Enable or disable the required protections.	The speed by which the AVR ramps from the minimum setpoint to the nominal setpoint.	Special application		Enable or disable the required modes of operation	Enable or disable the required modes of operation

* Used only by manufacturer. Contact for more information.

** LX_VMA unit required.

Default factory settings are highlighted in table. By setting both M-Select and I-Limit at position 9 and placing the programming jumper, will reset the AVR to **default factory settings**.

WIRING DIAGRAM I

AVR with Auxilary winding (Self excited)

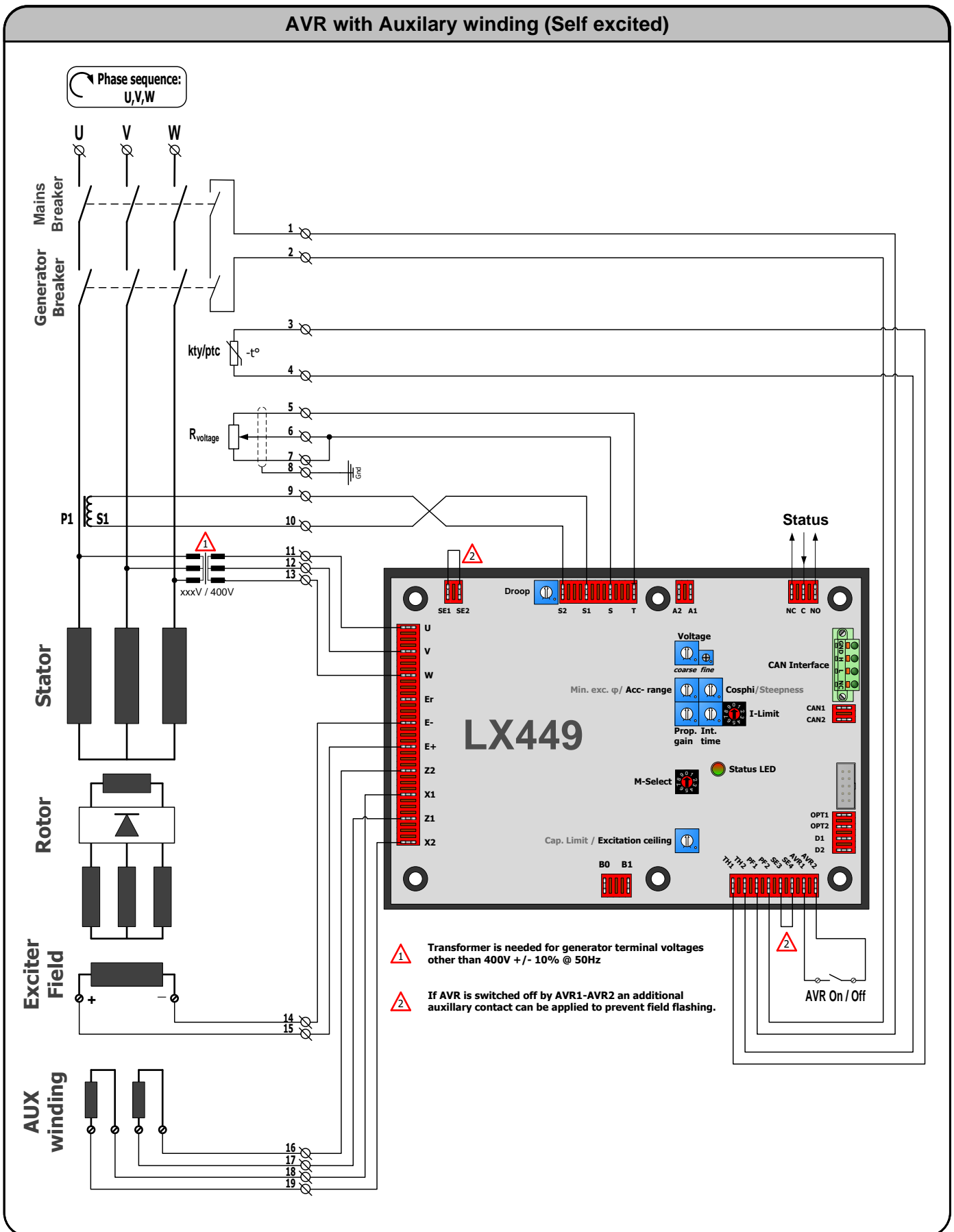

WIRING DIAGRAM II

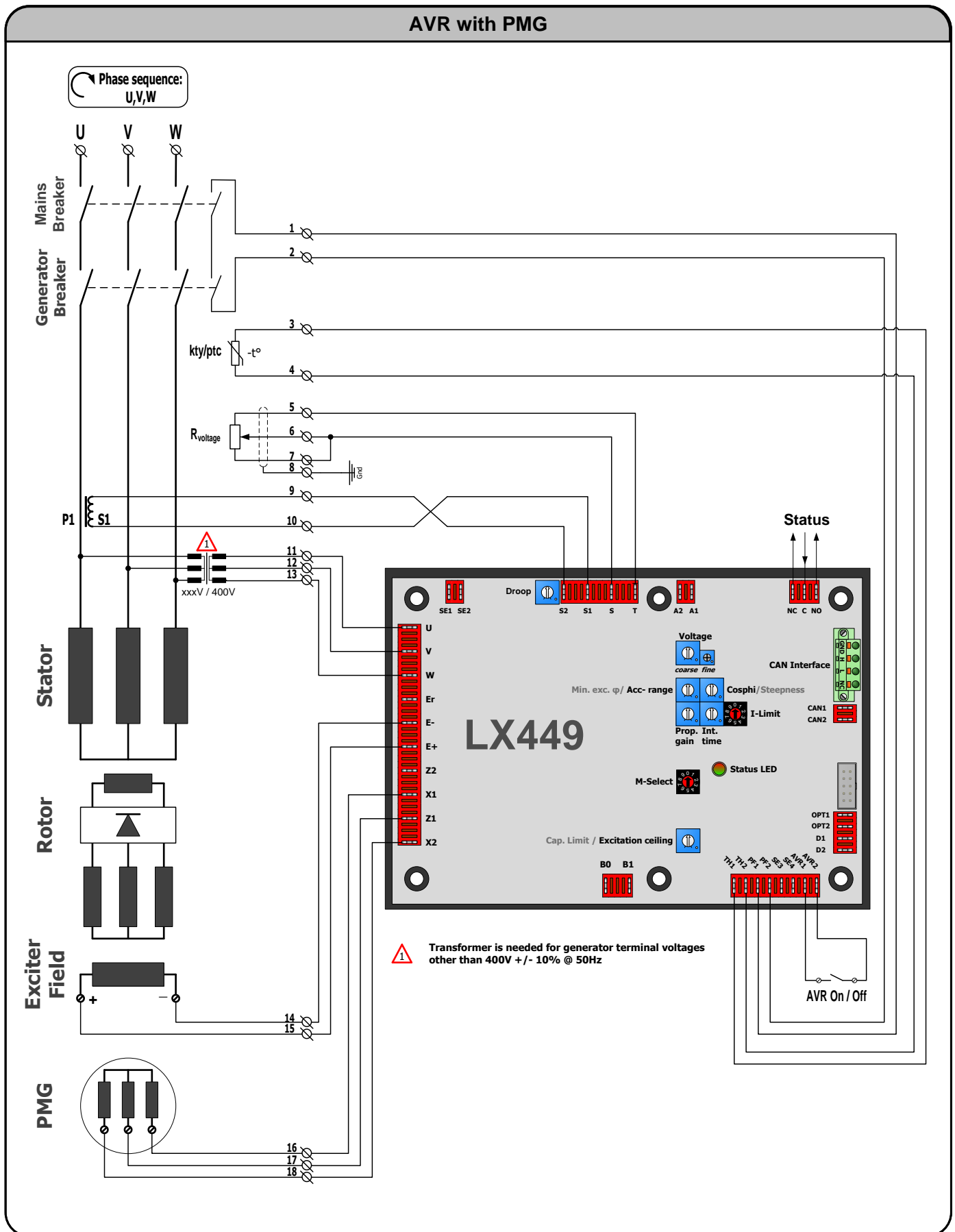

WIRING DIAGRAM III

AVR with Transformer (Self excited)

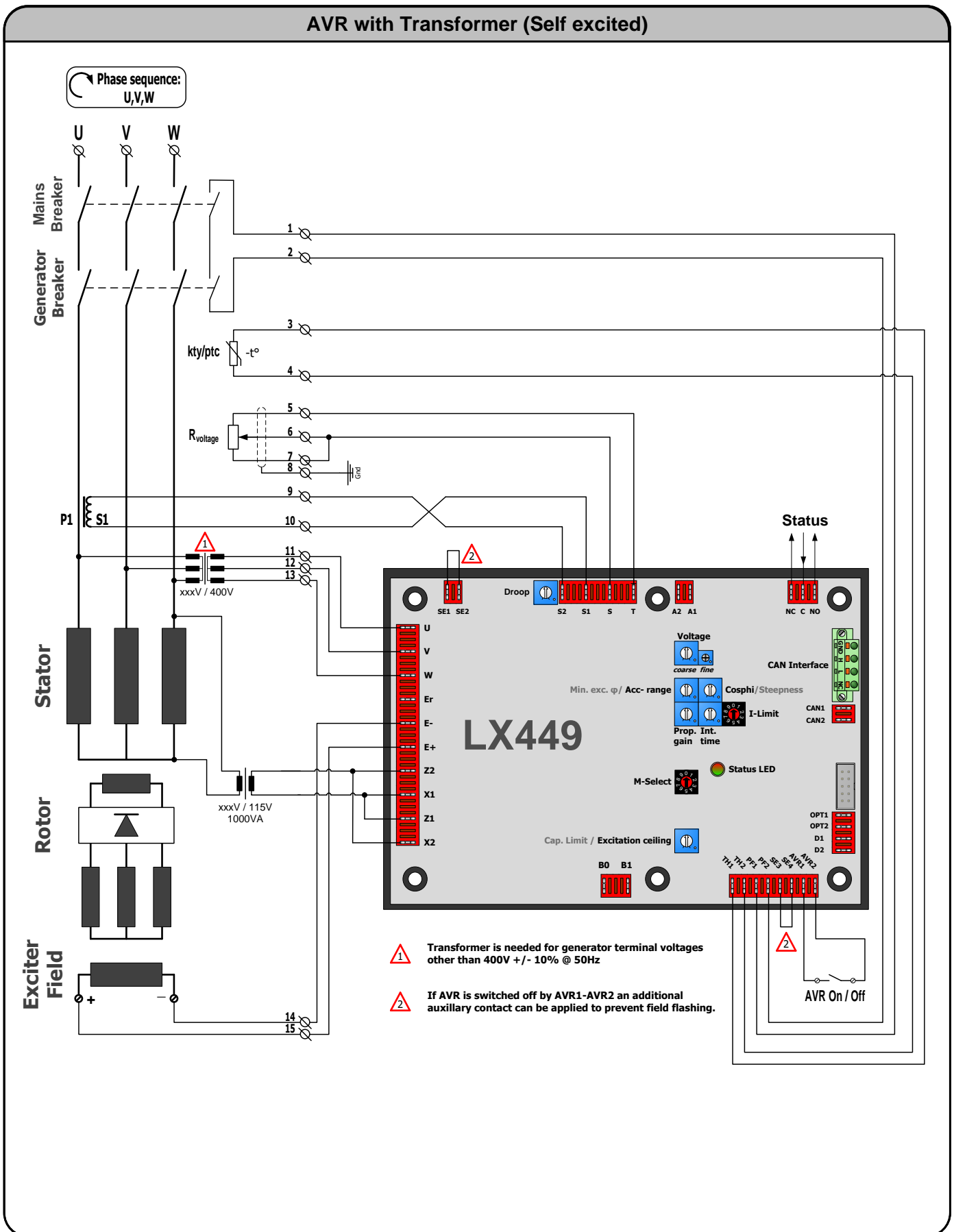

WIRING DIAGRAM IV

AVR Inverted operation

Adv.
Setting

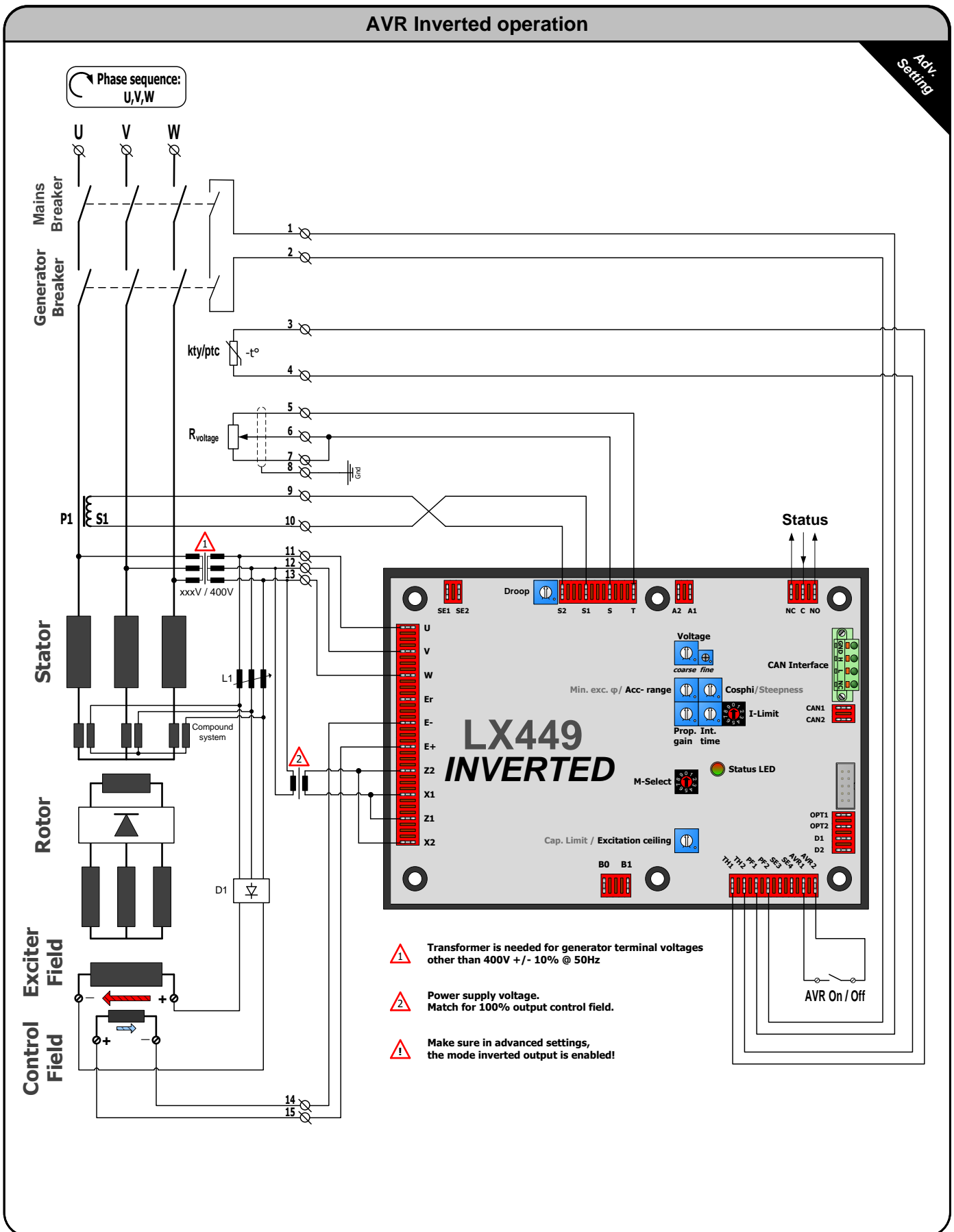

WIRING DIAGRAM

AVR subtractive operation

Adv.
Setting

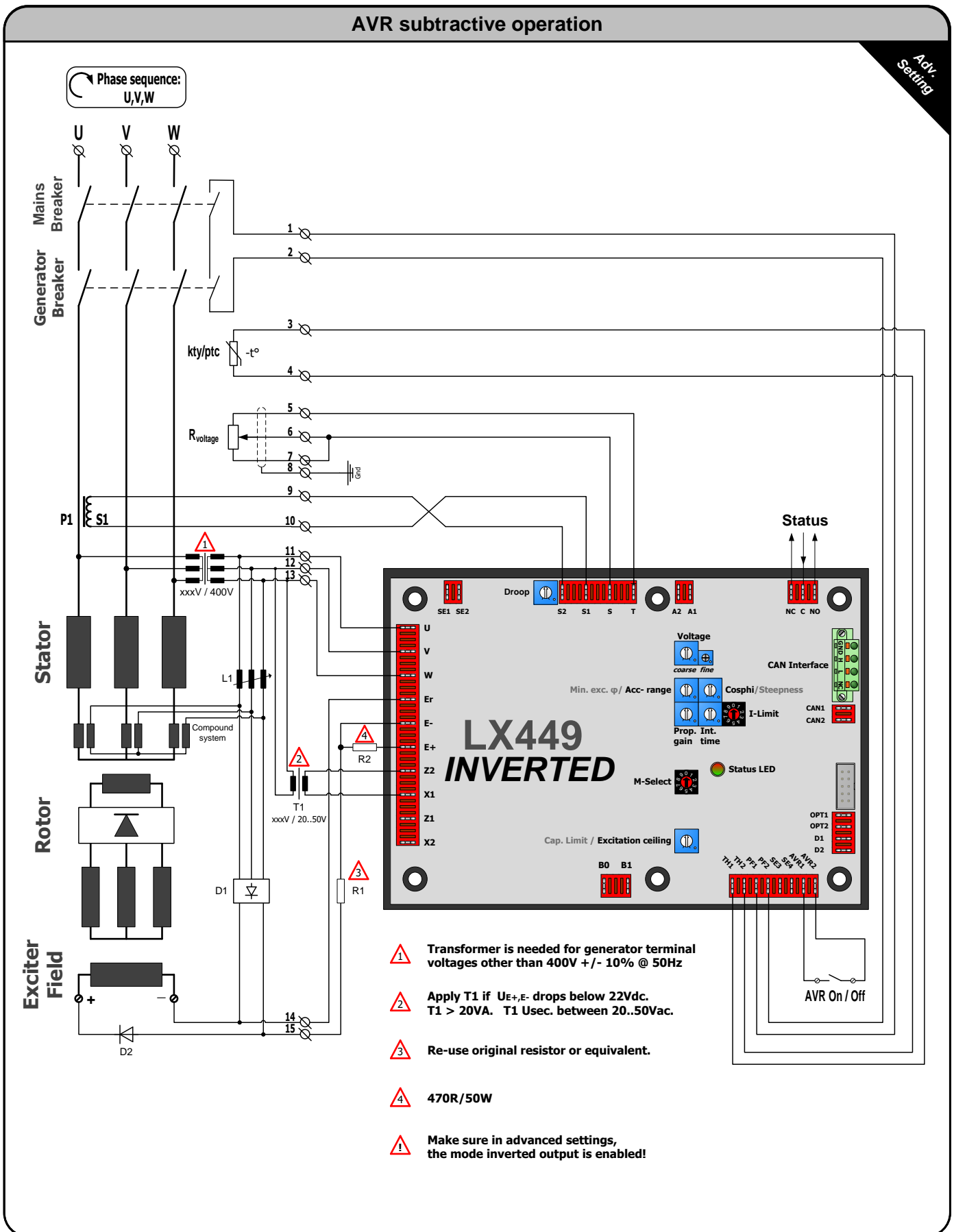

GENERAL INSTALLATION INFORMATION

Absolute Maximum Ratings

- The Absolute Maximum Ratings are those limits for the device that, if exceeded, will likely damage the device. Exceeding the absolute maximum ratings voids any warranty and/or guarantee.

Mounting

Mounting of the product should be done in such a way that:

- the absolute maximum ambient temperature rating of the product will never be exceeded.
- maximum cooling (direction of cooling ribs and direction of airflow) is achieved.
- Mounting no humid air can flow through the product or condensation occurs.
- dust or other materials or residue will not remain in or on the product.
- the maximum vibration is not exceeded.
- personal contact with persons is impossible.

Wiring

- Diameter size of the wiring should be enough to carry the expected current. Wire insulation should be enough to withstand the expected operating voltages and temperatures.
- To improve EMC emission and immunity, care should be taken for the lay out of the wiring. This in respect to all wiring in the installation.
- Keep current carrying wires as short as possible.
- Keep wires carrying a total sum of zero Ampere close to each other, or in one single cable, E.g. U, V, W, or E(+) and E (-), or Phase and neutral, or S and T.
- Avoid current carrying conductors next to sensing or control wiring. Especially current controlled by SCR's or PWM controlled transistors.
- If sensitive sensing signal cables need to be laid across distance along other cabling, shielded cable is preferred. Keep the shield as long as possible and the wiring outside the shield as short as possible. Do not solder or shrink the shield to a regular wire. Connect the original shield to ground at one side with an as large as possible contact surface.

Additional installation information

- When the product is supplied by means of a transformer, it should never be an auto-transformer. Auto-transformers react as voltage sweep up coil and may cause high voltage peaks.
- Standard fit capacitors or over-voltage suppressers across E(+) and E(-), or exciter field terminals inside the generator should be removed.
- When the product is supplied by means of a transformer, it should be able to carry at least the maximum expected current. Advisable is, to have a transformer which can carry twice the maximum expected current. Inductive loads make voltage sags and peaks into the secondary voltage of a transformer, from which the device may malfunction.
- It is not recommended to apply switches in dc outputs. It is preferred to use switches in the ac supply inputs of devices. In case it is unavoidable to have switches in the dc output of a device, action must be taken to avoid over voltage damage to the device due to contact arcing. Use a voltage suppressor across the output.
- It is not recommended to apply switches or fuses in the sensing lines. Defects can cause high voltage situations due to over-excitation.
- When using a step down transformer in medium or high voltage generators, the transformer should be three phase (if three phase sensing), and the transformer should be suitable for acting as a sensing transformer. If the transformer is unloaded, connect a resistor to avoid voltage waveform distortion.
- The phase relation from the generator to the AVR is important. Also when voltage transformers and/ or current transformers are installed.
- When using a step down or insulation transformer in the droop circuit, phase relation from the generator to the AVR is important.
- CT's wiring, connected to the AVR should never be grounded.
- Always disconnect electronic products, circuits and people before checking the insulation resistance (Megger check).
- Due to differences in generators impedance's, EMC behavior is not predictable. Therefore the commissioner / installer should be aware of proper and correct installation.
- Large, highly inductive, exciter stator windings can cause destructive high voltage peaks. Adding a resistor from 10 to 20 times the exciter stator field resistance reduces voltage spikes. If necessary filter can be fitted additionally. (e.g. snubber, RC-network)
- Upon problems during commissioning, faulty behavior or defects in the generator, consult the fault finding manual at our web site
- Some advises may be overdone or seem extraordinary, but since the electrical rules are the same everywhere, these advises are given.

CONTACT

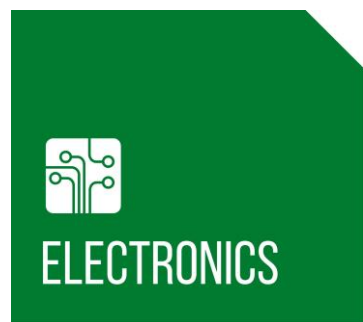

EMRI Electronics B.V.
Morsestraat 10
6716 AH, Ede, Netherlands
Tel: +31 (0)318 620 427
Website: www.emri.nl
E-mail: info@emri.nl

Manufacturer



CANARY ISLANDS, Las Palmas
Zamakona Yards
Tel: +34 928467521
Fax: +34 928461233
Website: www.zamakonayards.com/
E-mail: jbetancor@zamakonayards.com

CHILE, Santiago
Lucio Vicencio y CIA.LTDA
Tel: +1-281-334-2904
Fax: +1-832-221-5642
Website: www.luciovicencio.cl
E-mail: luciovincencioltda@gmail.com

GREECE, Piraeus
Stavros Kassidiaris S.A.
Tel: +30 210 4636000
Fax: +30 210 4624471
Website: www.kassidiaris.gr
E-mail: info@kassidiaris.gr

ICELAND, Hafnarfjordur
Rafeining ehf
Tel: +354 565 3049
Fax: +354 565 3048
Website: www.rafeining.is
E-mail: rafeining@rafeining.is

INDIA, Faridabad
Power Solutions
Tel: +91 9868907903
Fax: +91 129 2431216
Website: www.psolindia.com
E-mail: ramesh.powersolutions@gmail.com

NORWAY, Bergen
Frydenbø Electric A/S
Tel: +47 55 34 91 00
Fax: +47 55 34 91 10
Website: www.frydenbo.no
E-mail: firma.fel@frydenboe.no

POLAND, Gdynia
An-Elec Sp. z o.o.
Tel: +48 58 668 44 00
Fax: +48 58 668 44 66
Website: <http://an-elec.pl>
E-mail: info@an-elec.pl

POLAND, Szczecin
MARCONTREL
Tel: +48 91 4 888 474
Fax: +48 91 4 888 475
Website: www.marcontrol.com
E-mail: emri@marcontrol.com

POLAND, Szczecin-Mierzyn
Marel Serwis
Tel: +48 91 48 58 388
Fax: +48 91 48 79 948
Website: www.marel.szczecin.pl
E-mail: handel@marel.szczecin.pl

REPUBLIC OF PANAMA, Panama
PASRAS S.A.
Tel: +507 3140095
Fax: +507 3140094
Website: www.pasras.com
E-mail: info@pasras.com

ROMANIA, Constanta
SAMTEC SRL
Tel: +40 241 517 047
Fax: +40 241 517 047
Website: www.samtec.ro
E-mail: samtec_srl@yahoo.com

SINGAPORE, Singapore
Cyclect Electrical Engineering
Tel: +65 6868 6013
Fax: +65 6863 6260
Website: www.cyclect.com.sg
E-mail: heng.p@cyclect.com.sg

SOUTH AFRICA, Roodepoort
Yneldo Electronics
Tel: +27(0)117637053
Fax: +27(0)117634212
Website: www.yneldo.com
E-mail: yneldo@yneldo.com

SWEDEN, Kungälv
Elektrisk Drivteknik EDT AB
Tel: +46-705-28 20 60
Tel: +46-709-50 47 90
Website: www.edtab.se
E-mail: info@edtab.se

THAILAND, Bang Lamung
Semtec Maritime/Genetech Co.Ltd
Tel: +66 38301262
Fax: +1-832-221-5642
Website: semtecmaritime.com/
Email: info@semtecmaritime.com

TURKEY, Izmir
INTEGRAL
Tel: +90 (555) 211 55 75
Email: ozgur@integralguc.com

UNITED ARAB EMIRATES, Sharjah
KDU Technical Services
Tel: +971-6-5575480
Fax: +971-6-5575490
Website: www.kdutech.ae
E-mail: kdutech@kdutech.ae

UNITED KINGDOM, Stockton on Tees
MJR Controls
Tel: +44 1642 762 151
Fax: +44 1642 762 502
Website: www.mjrcontrols.com
Email: chris.milner@mjrcontrols.com

UNITED KINGDOM, Cheadle Hulme
TGS Total Generator Solutions Ltd
Tel: +44161 8188720
Fax: +447754677963
Website: <http://totalgeneratorsolutions.com>
Email: sales@totalgeneratorsolutions.com

UNITED STATES, Kemah - Texas
Ramtec Marine Systems LLC
Tel: +1-281-334-2904
Fax: +1-832-221-5642
Website: www.ramtec-marine.com
Email: waling@ramtec-marine.com