



LXCOS_Lite

Reduced output, weight and height

Instruction Manual V1.0.1

Product version V1.0.1.0



**Marine approved
Smartgrid compliant**

EMRI ELECTRONICS
POWER IN CONTROL



WARNINGS AND COMMISSIONING INFORMATION



HAZARDOUS VOLTAGES.



DO NOT OPERATE WHEN NOT FAMILIAR WITH GENERATORS.

- **Check the isolation of the generator windings before installation.**
Poor isolation will cause damage to the AVR and dangerous situations for persons.
- The system should not be installed, operated, serviced or modified except by qualified personnel who understand the danger of electric shock hazards and have read and understood the user instructions.
- Never work on a LIVE generator. Unless there is another person present who can switch off the power supply or stop the engine.
- Dangerous voltages are present at the voltage regulator board. Accidental contact with live conductors could result in serious electrical shock or electrocution.
- Disconnect the power source before making repairs, connecting test instruments, or removing or making connections to the voltage regulator or generator.
- Defects in the generator or AVR may cause consequential loss. Precautions must be taken to prevent this from occurring.
- The unit should be installed with respect to the environmental specifications as well as the rules mentioned in the General installation information.
- For safety reasons the voltage level potentiometers are best turned completely counter clockwise in order to start at the lowest possible voltage.
- Never change the rotary switch or dipswitch settings during operation.
- Never apply supply voltage when generator is not running, unless exciter field is disconnected.

REVISION HISTORY

Product	Version				Change
	Hardware	Software	Manual	Date	
V1.0.0.0	1.0	1.5	1.0	Jan-2021	<i>First release.</i>
V1.0.1.0	1.0	1.5.1	1.0.1	Nov-2021	<i>Changed default setting for parameter "Global loop gain"</i>

The table provides a historical summary of the changes made to the AVR.
Revisions are listed in chronological order.

The manual does not cover all technical details of the product. Specifications may be modified by the manufacturer without notice. For further information, the manufacturer should be contacted.

TABLE OF CONTENTS

General description I & II	4
Absolute maximum ratings	6
Protections	7
Buildup	8
- <i>Buildup (PMG)</i>	- <i>Buildup (Self excite)</i>
M-Select	9
- <i>Constant voltage control</i>	- <i>Volt per Hertz control</i>
- <i>0-100% Voltage control</i>	- <i>0-100% Current control</i>
Primary adjustments	10
- <i>Setpoint control</i>	- <i>Remote adjust</i>
- <i>Stability control</i>	- <i>Droop</i>
- <i>I-Limit</i>	- <i>I-Limit (Motor start)</i>
Modes of control I	11
- <i>UF mode</i>	- <i>FCR mode</i>
- <i>SR2 mode</i>	- <i>FCR mode</i>
Modes of control II	12
- <i>QPF mode (PF Control)</i>	- <i>QPF2 mode (PF Control)</i>
- <i>kVAr mode</i>	- <i>UEL mode</i>
- <i>FCR1 / OEL</i>	- <i>FCR2 / OEL</i>
Modes of control III	13
- <i>Voltage matching</i>	- <i>CUN mode</i>
- <i>Frequency Knee offset</i>	- <i>Lock setpoints</i>
Raise / Lower I	14
- <i>Voltage control</i>	- <i>0..100% control</i>
- <i>QPF control</i>	- <i>QPF control</i>
Raise / Lower II	15
- <i>kVAr control</i>	- <i>FCR1 control</i>
- <i>FCR1 control</i>	- <i>FCR2 control</i>
- <i>FCR2 control</i>	- <i>FCR2 control</i>
Quick reference I & II	16
- <i>Hardware connections</i>	- <i>Factory settings</i>
Quick reference III & IV	18
- <i>Rotary switches</i>	- <i>Dipswitches</i>
- <i>Potentiometers</i>	- <i>Status LED</i>
Advanced settings I & II	20
- <i>AVR Configuration options (QPF, QPF2, SR2, UF, ER1, CUN, FCR, kVAr)</i>	- <i>AVR Configuration options (QPF, QPF2, SR2, UF, ER1, CUN, FCR, kVAr)</i>
Advanced settings III & IV	22
- <i>Programming advanced settings with rotary switches (AVR)</i>	- <i>Programming advanced settings with rotary switches (AVR)</i>
Advanced settings v	24
- <i>Programming advanced settings with AVR Assistant</i>	- <i>Programming advanced settings with AVR Assistant</i>
Priority level	25
CAN Interface	25
Wiring diagrams	26
General installation information	31
Contact	32

GENERAL DESCRIPTION I

The AVR has the same outline and functions as the EMRI LXCOS.

The difference between the AVR and the EMRI LXCOS is that the height is reduced by 20mm and the excitation current is reduced to a maximum of 3.5A continuously.

Other options are available with separate units, see table options.

Nevertheless installation, maintenance and adjustment doesn't require special application software. The AVR is protected from the environment by a PUR coating.

Available modes of control		AVK module
Constant voltage control		
Volt per Hertz control		UF
Quadrature voltage droop for parallel operation		
Raise / Lower control		
0-100% generator current control		
0-100% generator voltage control		ES
Generator current limiting		SR2
Voltage matching		CUN
Power factor control (PFC)		QPF
kVAr regulation		QPF
Field Current Regulation (FCR)		
Protection		
Generator phase loss & phase sequence		
AVR over temperature		
Generator over temperature		
Generator over voltage		
Generator over current		
Generator over excitation current		
Loss of excitation during PFC		
Loss of current sensing during PFC		
User adjustable underspeed knee		UF
User adjustable under excitation current		ER1
User adjustable over excitation current		ER1
User adjustable generator current limit		SR2
Communication		
AVR Status LED		
AVR Status contact		
CAN bus		

Options		Terminals	AVK module
AVR Assistant	Handheld programming and monitor device	CAN	
DROOPKIT	Required for Droop, PF Control, Current Limiting	k - l	
LX_VMA	Required for voltage matching	A1 - A2	CUN
3F-Filter	For filtering the generator sensing voltage	U - V - W	TF1-50
DFD7.5	Diode failure detector	Separate unit	
CLC	Cable Loss Compensation unit	Separate unit	KP
AFD	Dual channel AVR for generators	Separate unit	SB2
RunDect	Motor stall protection & End of run-up detection	Separate unit	
Jump R500	0-20mA shunt for accessoires input (0-10Volt)	A1 - A2	
Jump R121	0-20mA shunt for QPF2 setpoint	TH1-TH2	
	0-20mA shunt for remote adjust	s-t	

GENERAL DESCRIPTION II

Marine applications:

The automatic voltage regulator has been tested satisfactory in accordance with the relevant requirements of the Lloyds Register Type Approval System for marine applications.

Lloyd's Register Type Approval System

Test Specification Number 1 07/15

Certificate : GRO.TA 1605 214 HLR & No. 17.30044

Defence / Navy applications NSN 5963-17-126-7799, HG H2H29

Smart-grid:

The automatic voltage regulator is compliant for applications in generators - power generation sets which should meet:

Smartgrid BDEW Technische Richtlinie „Erzeugungsanlagen am Mittelspannungsnetz”.
Dynamic grid support.
Low voltage ride through (LVRT).
Under voltage ride through (UVRT).
High voltage ride through (HVRT).
Contribution to short-circuit.
Reactive power control strategies ($\cos \varphi$).

VDE-AR-N-4100:2019-04
VDE-AR-N-4105:2019-04

CE Compliance:

Conductive emission:	EN 55016-2-1
Radiated emission:	EN 55016-2-3 + A1 + A2 + C1
Electro Static Discharge (ESD):	EN-IEC 61000-4-2
Radiated Immunity	EN-IEC 61000-4-3 + A1 + A2
Electrical Fast Transient (EFT):	EN-IEC 61000-4-4
Surge Immunity:	EN-IEC 61000-4-5
Conductive Immunity:	EN-IEC 61000-4-6

ABSOLUTE MAXIMUM RATING

Symbol	Parameter	Condition	Min.	Max.	Unit
U, V, W	Voltage sensing input ⁽²⁾ ⁽⁶⁾	50Hz, continuous	-	450	V _{AC}
		50Hz, Intermitted < 30s.	-	480	V _{AC}
		60Hz, continuous	-	500	V _{AC}
		60Hz, Intermitted < 30s.	-	520	V _{AC}
		Burden	-	5	VA
I1, K1	AVR field current	Continuous ⁽¹⁾ ⁽⁷⁾	-	3.5	A _{DC}
		Intermitted < 10s.	-	15	A _{DC}
	Field resistance I1(+), K1(-)	@ 70V _{AC} supply ⁽⁴⁾ ⁽⁵⁾	5	-	Ω
		@ 170V _{AC} supply	12	-	Ω
UH1-UH2 VH1-WH2 UH1-VH1-WH1	Supply input	UH1-UH2, WH1-WH2,	15	240	V _{AC}
		UH1-VH1-WH1 DC or 25 - 400Hz	15	135	V _{DC}
A1, A2	Accessories input ⁽²⁾	A1(+), A2(-) ⁽³⁾	-13	+13	V _{DC}
k, l	Droop, PFC, Limit CT ⁽²⁾	Isolated CT > 2VA, Intermitted < 30s.	-	1.5	A _{AC}
T _{AMB}	Operating temperature	95% RHD non condensing ⁽¹⁾	-40	+70	°C
T _{STG}	Storage temperature	95% RHD non condensing	-40	+70	°C
	Static control accuracy			1	%

- ⁽¹⁾ Always mount with heatsink fins aligned vertically and allow for sufficient airflow.
⁽²⁾ Isolated input. ⁽⁵⁾ See formula for calculating minimum field resistance.
⁽³⁾ Input resistance is 10KΩ. ⁽⁶⁾ Depending on voltage selection
⁽⁴⁾ See table below for safe operation area of the AVR. ⁽⁷⁾ For higher continuous excitation current, see standard LXCOS.



$$\text{Field resistance } (\Omega) \geq \frac{\text{Supply input} \times \sqrt{2} \text{ (V}_{DC}\text{)}}{20}$$



Stresses above “Absolute Maximum Ratings” may cause permanent damage to the device. This is a stress rating only, the functional operation of the device or any other conditions indicated in the “operation area” of this specification is not implied. Exposure to maximum rating conditions for extended periods may affect device reliability and lifetime.

Operating Area

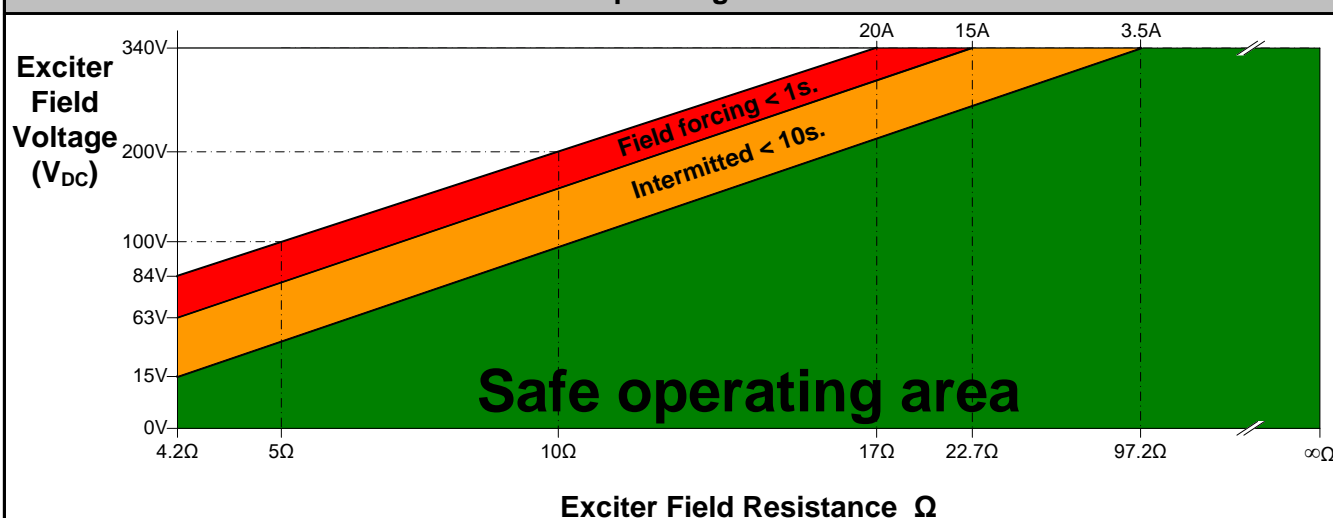

Exciter Field Voltage = Supply input x $\sqrt{2}$ (V_{DC})

PROTECTIONS

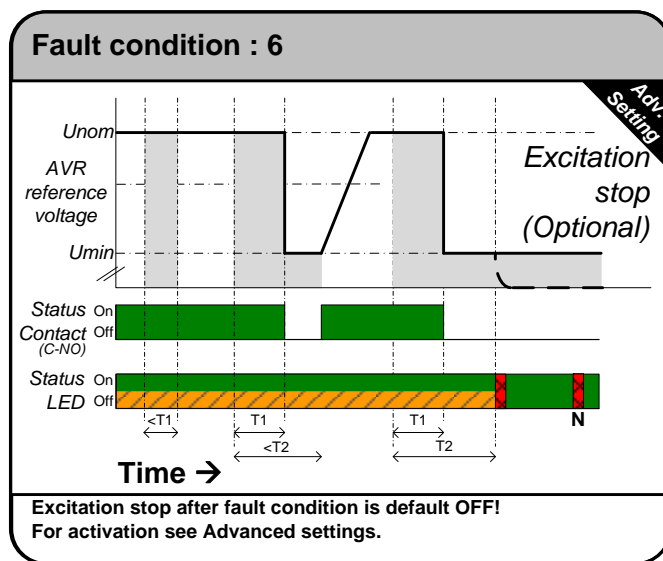
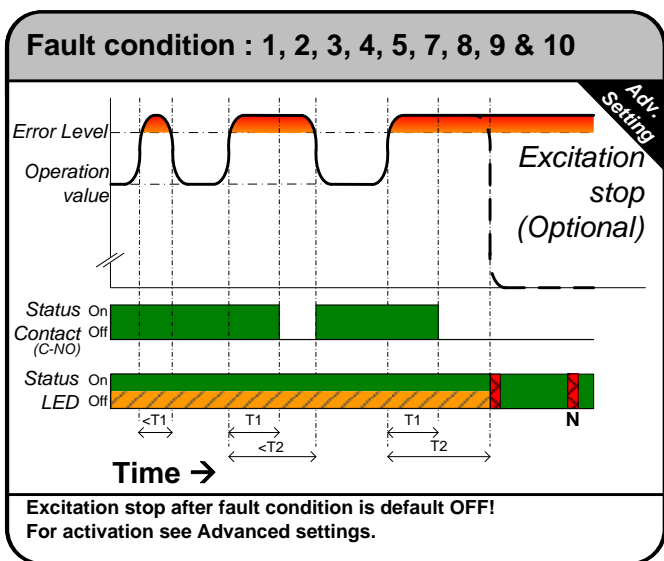

Protection	N	Fault Condition	T1	T2	
Over voltage	1	135V @ 100V sensing 257V @ 200V sensing 508V @ 400V sensing	M-Select 8 & Underspeed 47Hz ⁽¹⁾	1 s.	2 s.
		155V @ 100V sensing 300V @ 200V sensing 585V @ 400V sensing	M-Select 9 & Underspeed 57Hz ⁽¹⁾		
Over current	2	300% at current sensing input k-l	2 s.	4 s.	
Over excitation	3	125% of Exc. Ceiling setpoint	0.3 s.	10 s.	
Over temperature AVR	4	85 °C	10 s.	20 s.	
Over temperature generator	5	1K8 < R _{TH1-TH2} < 3K	10 s.	15 s.	
Loss of sensing	6	Loss of sensing	2.5 s.	5 s.	
Loss of excitation during PFC	7	Excitation current < 250mA ⁽²⁾	5 s.	6 s.	
Loss of current sensing during PFC	8	Current sensing < 2.5% ⁽²⁾	5 s.	6 s.	
Sensing sequence error	9	Sensing sequence error ⁽²⁾	2.5 s.	5 s.	
100% excitation	10	Output excitation voltage 100% ⁽³⁾	2.5 s.	5 s.	

Excitation stop after fault condition is default OFF! For activation see Advanced settings III & IV.
⁽¹⁾ See Quick Reference III (M-Select : Underspeed selection with TH1-TH2).
⁽²⁾ AVR (excitation) remains active. ⁽³⁾ AVR (excitation) stops.

When a fault condition is active for more than time **T1**, the status contact deactivates.
 When a fault condition is active for more than time **T2**, the fault is indicated by the status led with **(N)umber of red blinks**.

When protection “Stop at fault” is ON, the AVR stops field excitation due to a fault.
 To **reset** the fault, open contact **AVR1-AVR2** for at least 10s, the AVR returns in idle mode.

In self excitation mode you must shut down the generator.
 Check fuse if AVR is not working.

BUILDUP

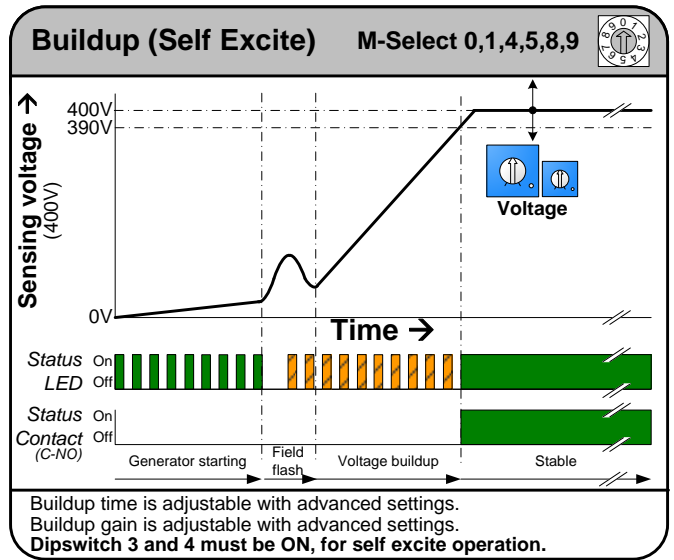
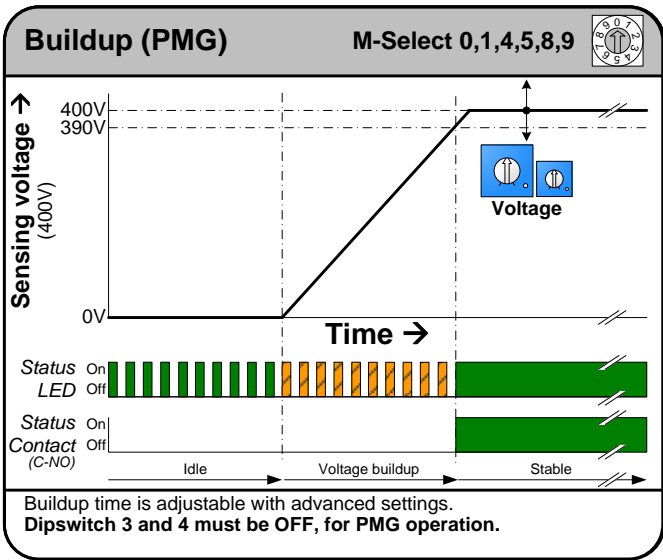

M-SELECT

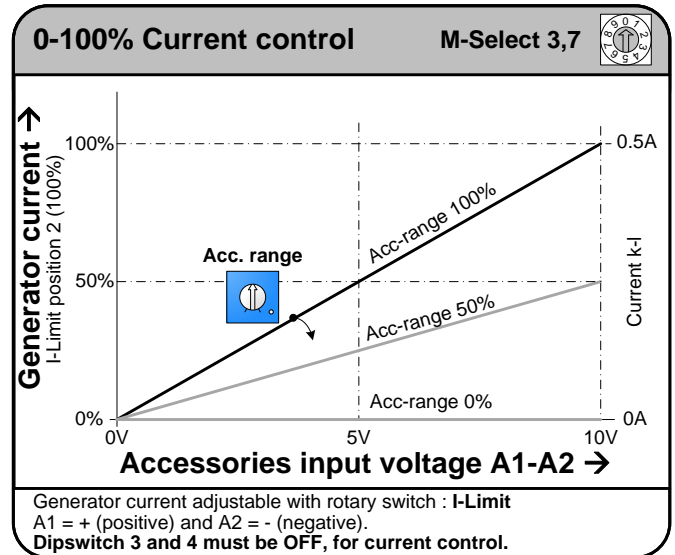
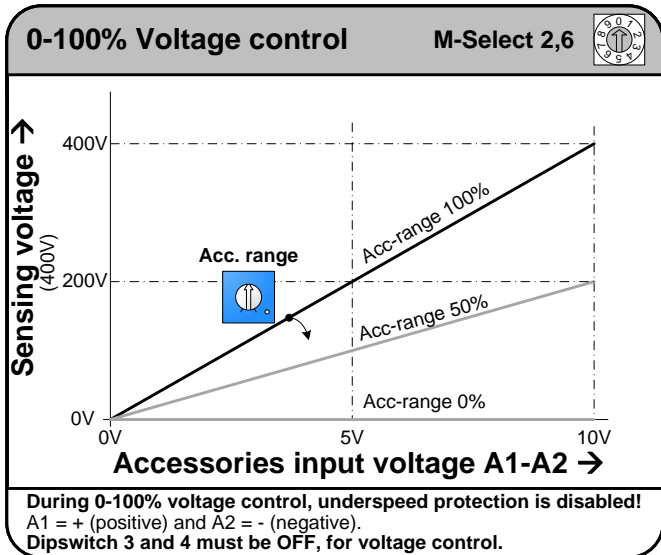
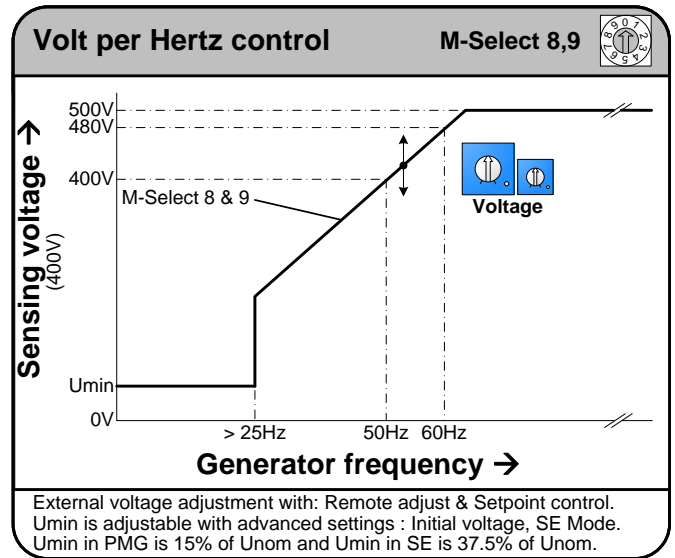
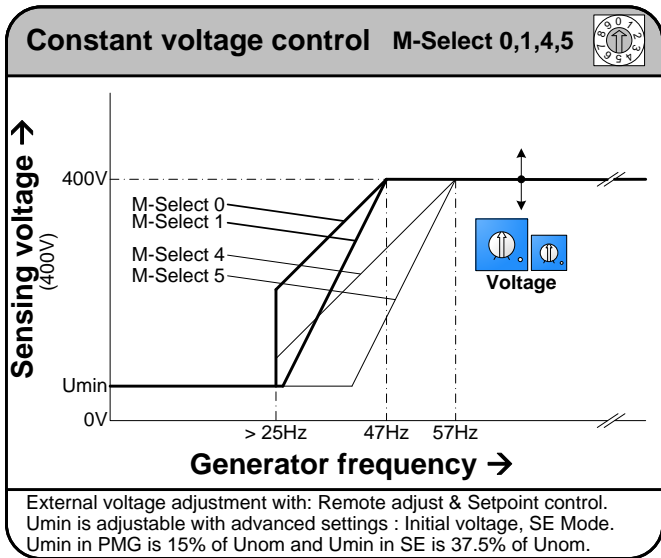

PRIMARY ADJUSTMENTS

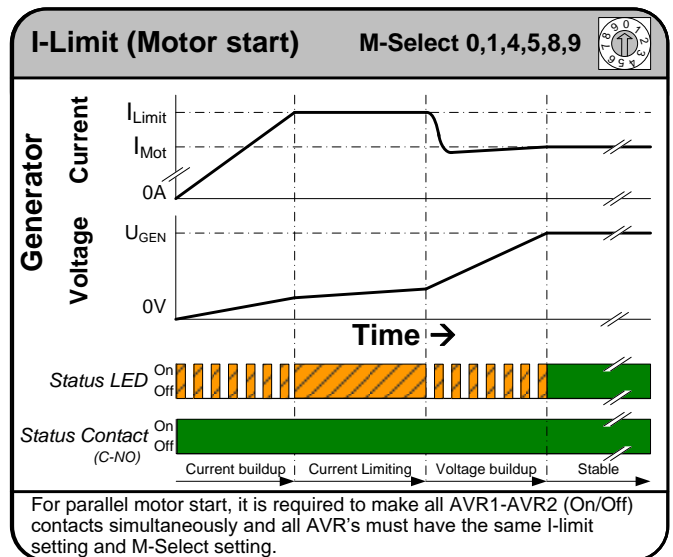
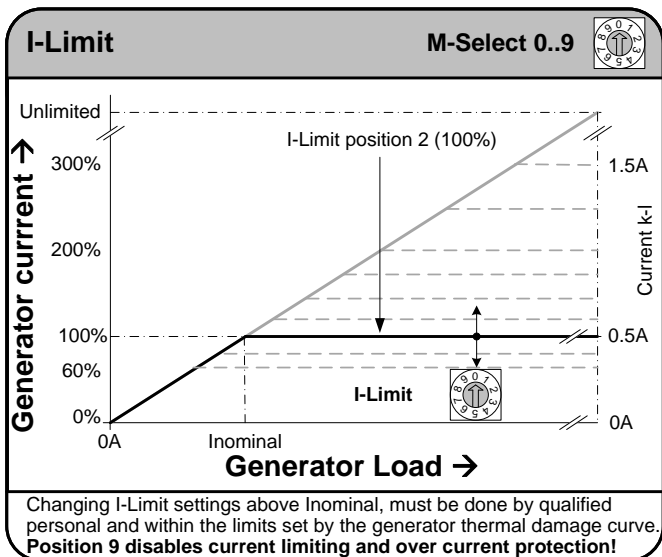
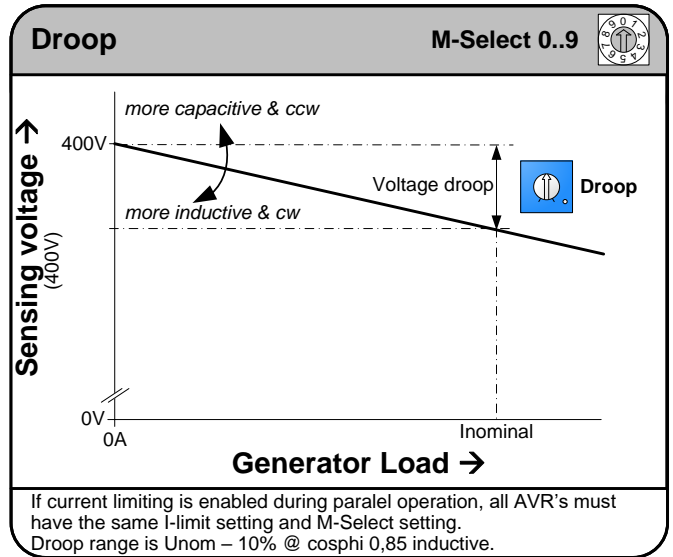
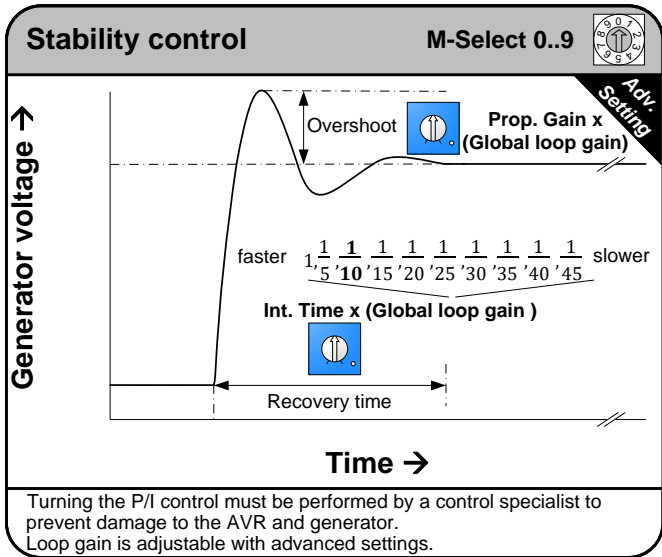
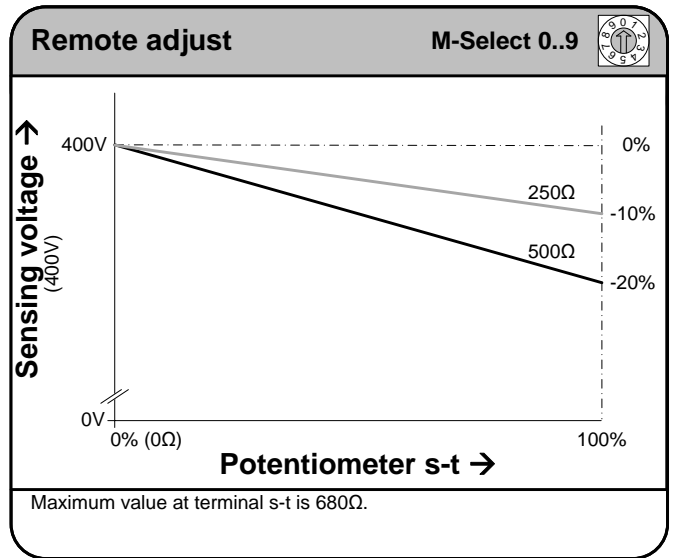
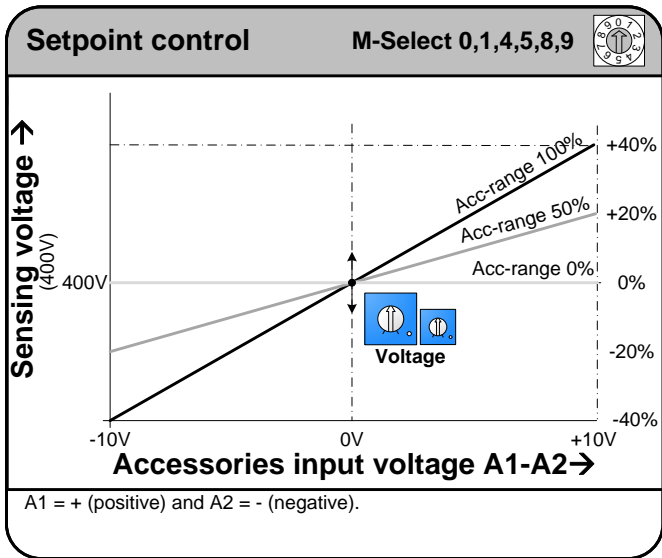

MODES OF CONTROL I

UF mode
M-Select 0,1,4,5,8,9

Adv. Setting

Sensing voltage →

400V

Umin

0V

>25Hz

50Hz

Generator frequency →

Steepness (3..17V/Hz)

Voltage

Knee Hz (30..60Hz)

Open = UF mode not active
Closed = UF mode active

Adjust sequence :

- 1: Set engine prime mover to nominal speed.
- 2: Set generator voltage with potentiometer "Voltage".
- 3: Turn potentiometer "Steepness" completely counter clockwise.
- 4: Close contact to activate UF mode.
- 5: Set engine prime mover to knee_point. (response speed)
- 6: Turn "Knee Hz" slowly clockwise until status led blinks green-orange.
- 7: Turn "Knee Hz" very slowly counter clockwise until led is continuous green.
- 8: Set engine prime mover to the required speed.
- 9: Set generator voltage with potentiometer "Steepness".

Enable UF mode with advanced settings and activate with contact. See "Advandec settings I & II" for setting Acc. range & OEL.

SR2 mode
M-Select 0,1,4,5,8,9

Adv. Setting

I-setpoint

% of I-Limit

ILimit

IMot

0A

UGEN

0V

Time →

Open = No current limiting!
Closed = SR2 Mode active

Enable SR2 mode with advanced settings and activate with contact. See "Advandec settings I & II" for setting Acc. range & OEL.

FCR mode
M-Select 0..9

Adv. Setting

Excitation →

10A

0A

Time →

FCR contact closed

FCR max (0..10A)

Open = FCR not active
Closed = FCR active

Enable FCR mode with advanced settings and activate with contact. During FCR mode, underspeed protection is disabled and there's no generator voltage regulation!

MODES OF CONTROL II

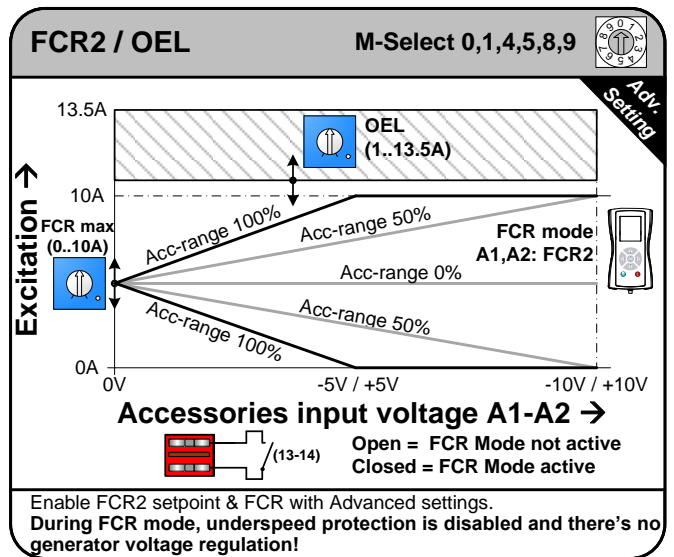
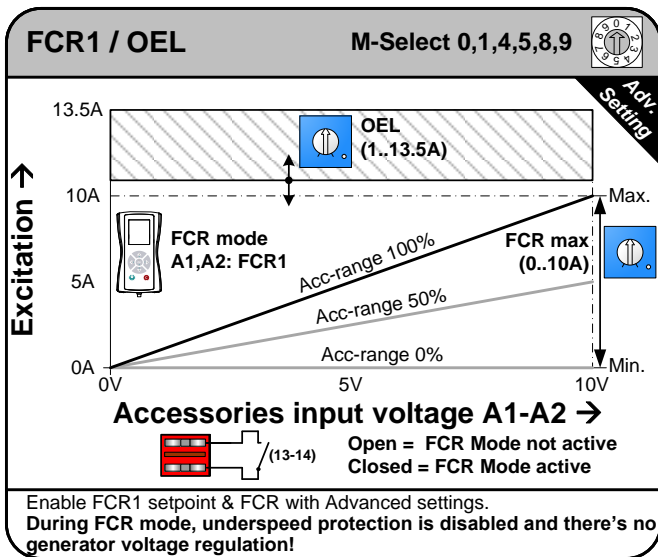
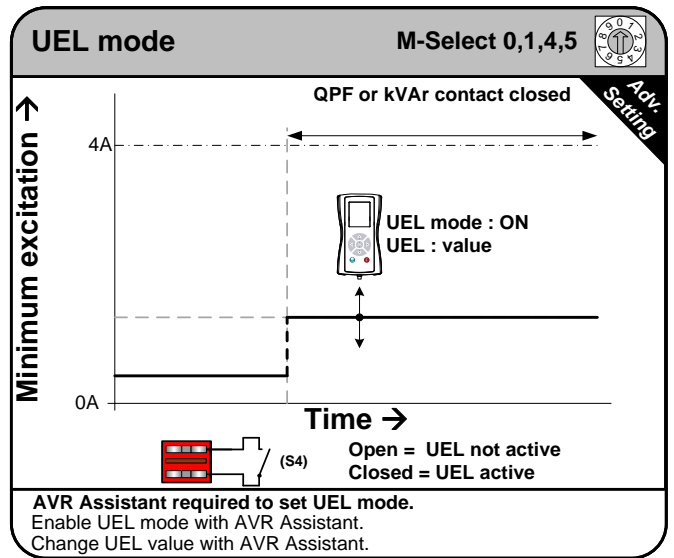
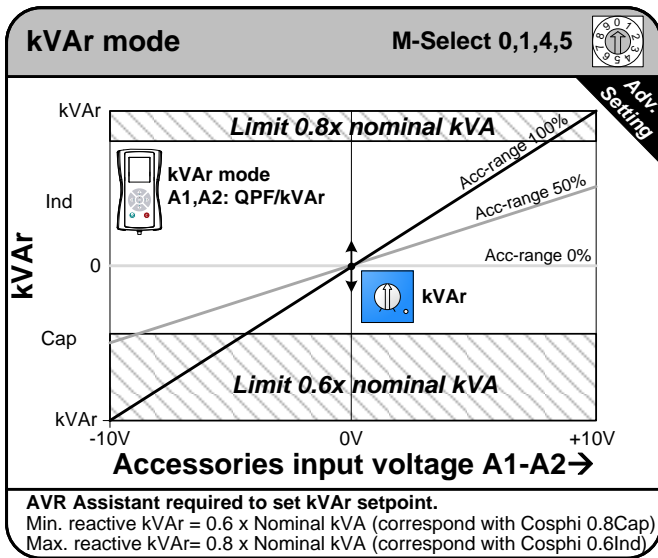
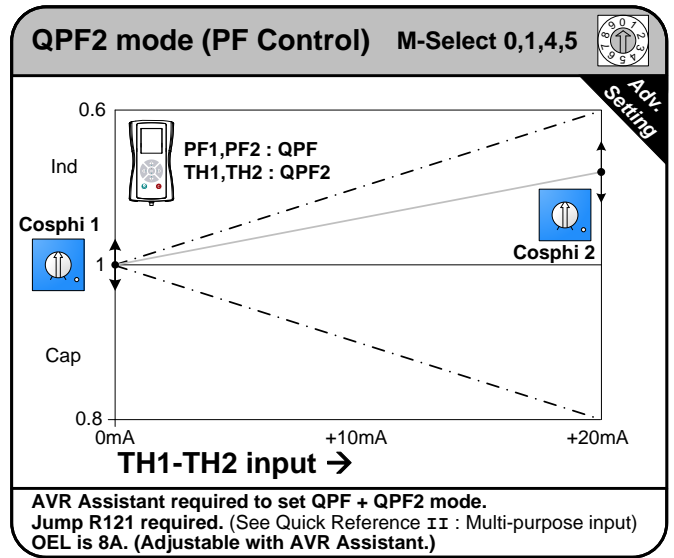
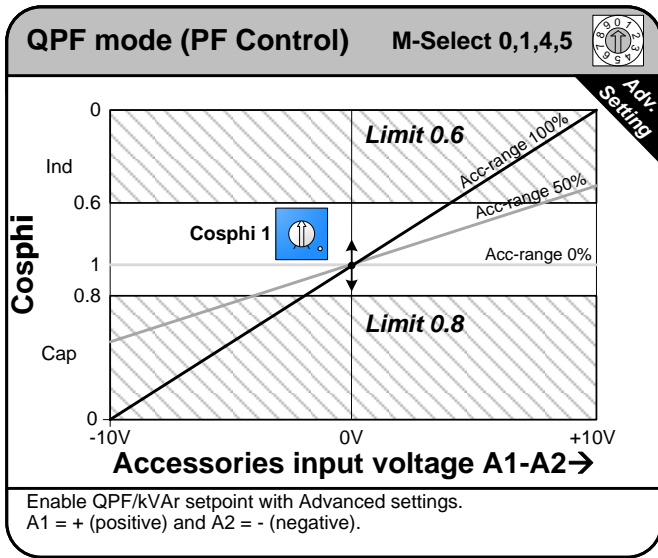

MODES OF CONTROL III

Voltage matching M-Select 0,1,4,5 

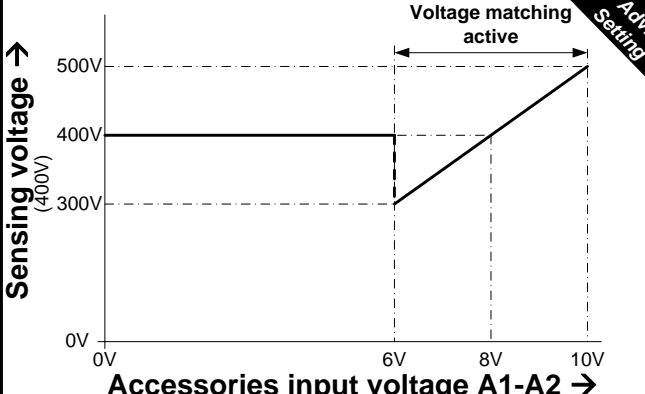

EMRI LX_VMA unit required for voltage matching".
Enable voltage matching with advanced settings.
A1 = + (positive) and A2 = - (negative).

CUN mode M-Select 0,1,4,5 

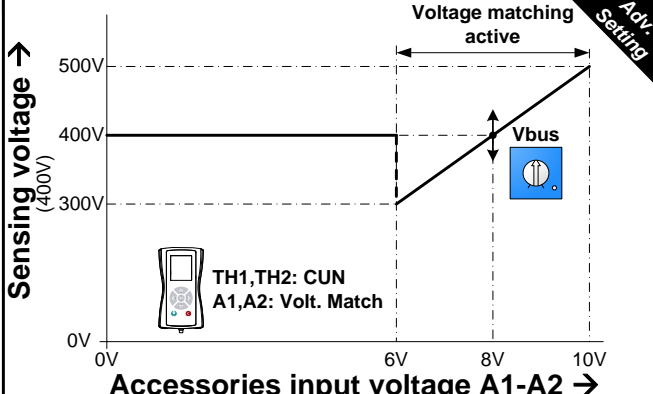

EMRI LX_VMA or other converter required for CUN mode .
Enable CUN & Volt. Match with AVR Assistant.
A1 = + (positive) and A2 = - (negative).

Frequency Knee offset M-Select 0,1,4,5 

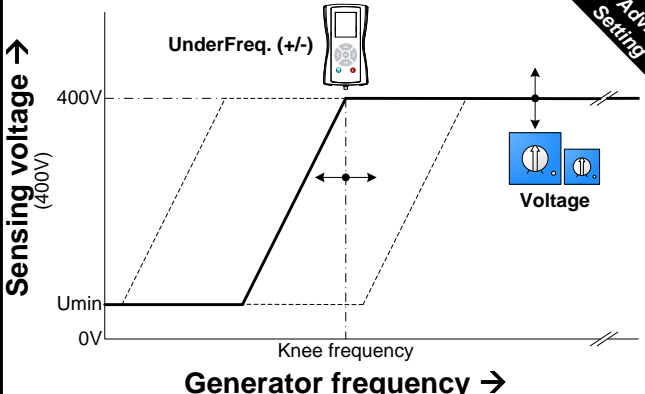

AVR Assistant required to set 'Frequency Knee offset'.
Change value UnderFreq.(+/-) with AVR Assistant.
Range UnderFreq.(+/-) = -12.7Hz .. +12.7Hz.

Lock setpoints M-Select 0..9 

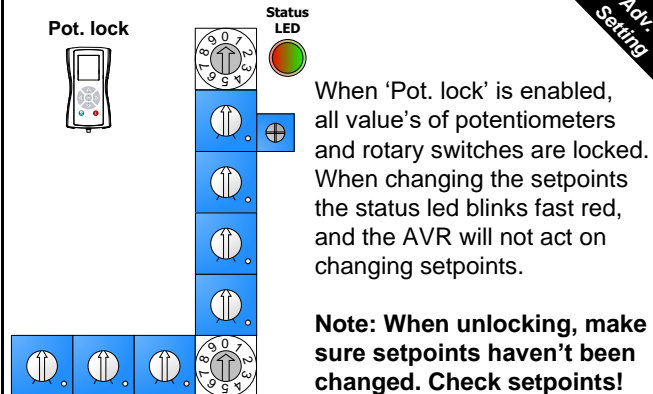

When 'Pot. lock' is enabled, all value's of potentiometers and rotary switches are locked. When changing the setpoints the status led blinks fast red, and the AVR will not act on changing setpoints.

Note: When unlocking, make sure setpoints haven't been changed. Check setpoints!

AVR Assistant required to set 'Lock setpoints'.
Enable 'Pot. lock ' with AVR Assistant.

RAISE / LOWER I

Raise / Lower voltage control

M-Select 0,1,4,5,8,9 

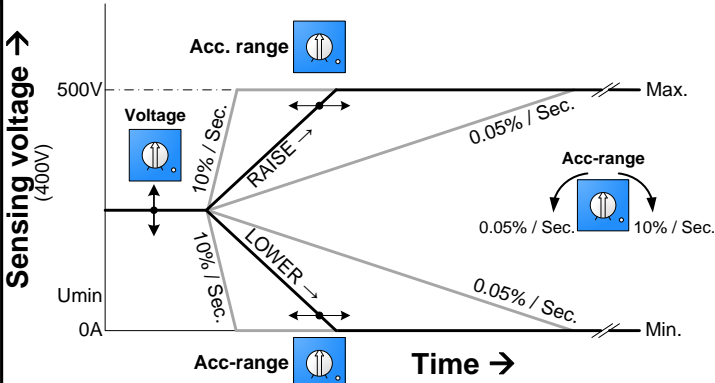

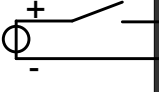
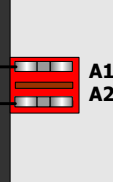
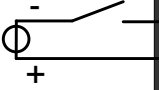
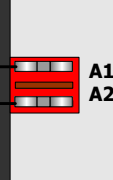
RAISE	12Vdc		
LOWER	12Vdc		

Enable Raise / Lower setpoint with rotary switches (advanced settings III & IV) or set " A1,A2: M-Select R/L " with AVR Assistant.
Voltage will rise to latest setpoint, only when supply has been shutdown (> 10sec) the voltage will rise to setpoint set with potentiometer Voltage !
 Umin in PMG is 15% of Unom and Umin in SE is 37.5% of Unom. Umin is adjustable with advanced settings : Initial voltage, SE Mode.

Raise / Lower 0..100% control

M-Select 2,3,6,7 

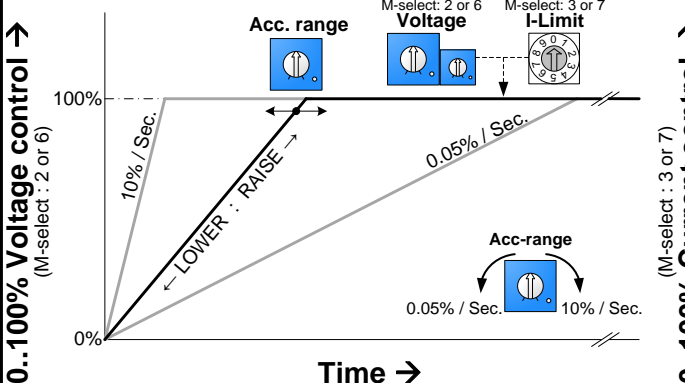

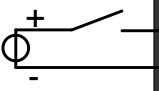
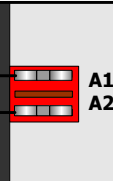
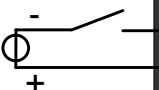
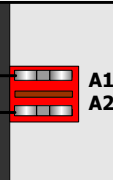
RAISE	12Vdc		
LOWER	12Vdc		

Enable Raise / Lower setpoint with rotary switches (advanced settings III & IV) or set " A1,A2: M-Select R/L " with AVR Assistant.
Voltage/Current will rise to latest setpoint, only when supply has been shutdown (> 10sec) the voltage start from 0% !
 During 0-100% voltage control, underspeed protection is disabled! Dipswitch 3 and 4 must be OFF, for 0..100% control.

Raise / Lower QPF control

M-Select 0,1,4,5 

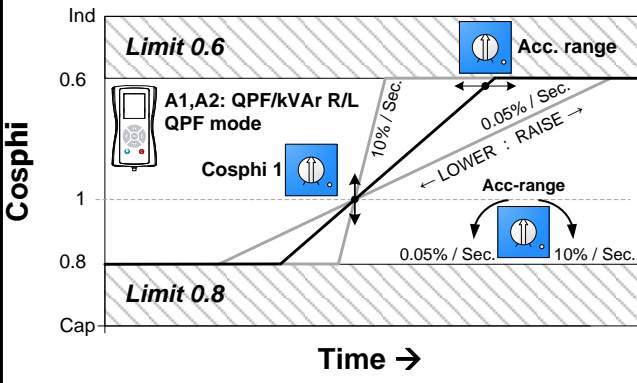

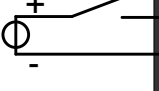
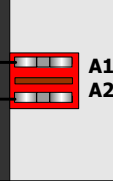
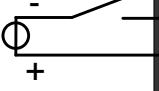
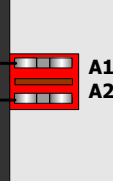
RAISE	12Vdc		
LOWER	12Vdc		





Enable Raise/Lower & QPF/kVAr setpoint with rotary switches (advanced settings III & IV) or set " A1,A2: QPF/kVAr R/L & QPF mode " with AVR Assistant.
PF will rise to latest setpoint, only when supply has been shutdown (> 10sec) the PF will rise to setpoint set with potentiometer CospHi !

RAISE / LOWER II

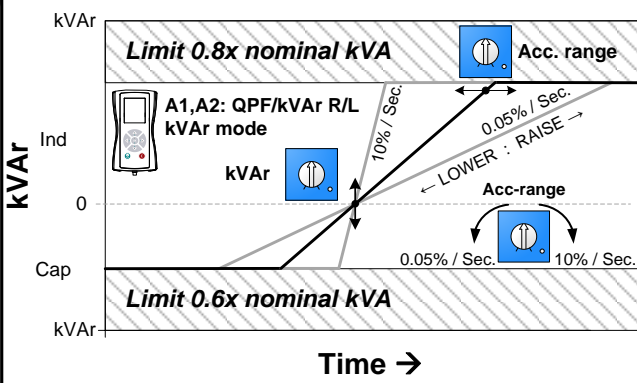
Raise / Lower kVAR control

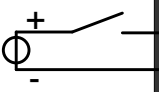
M-Select 0,1,4,5 

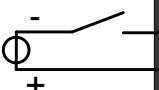

RAISE	12Vdc		
LOWER	12Vdc		



Time →

AVR Assistant required to set Raise / Lower kVAR control.
PF will rise to latest setpoint, only when supply has been shutdown (> 10sec) the PF will rise to setpoint set with potentiometer kVAR !
 Max. reactive kVAR = 0.8 x Nominal kVA (correspond with Cosphi 0.6Ind) Min. reactive kVAR = 0.6 x Nominal kVA (correspond with Cosphi 0.8Cap)

Raise / Lower FCR1 control

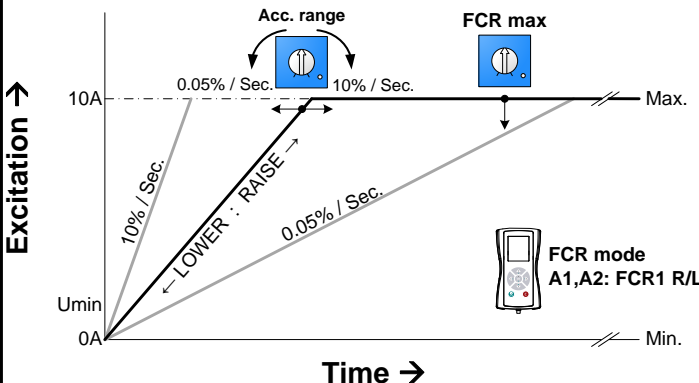
M-Select 0..9 

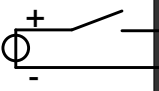

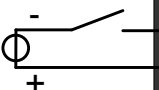
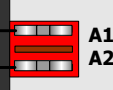
RAISE	12Vdc		
LOWER	12Vdc		

Time →

Enable Raise/Lower & FCR1 setpoint with rotary switches (advanced settings III & IV) or set " A1,A2: FCR1 R/L & FCR mode " with AVR Assistant.
The excitation will start from latest setpoint, only when supply has been shutdown (>10sec) the excitation starts from 0A!
During FCR mode, underspeed protection is disabled and there's no generator voltage regulation!

Raise / Lower FCR2 control

M-Select 0..9 

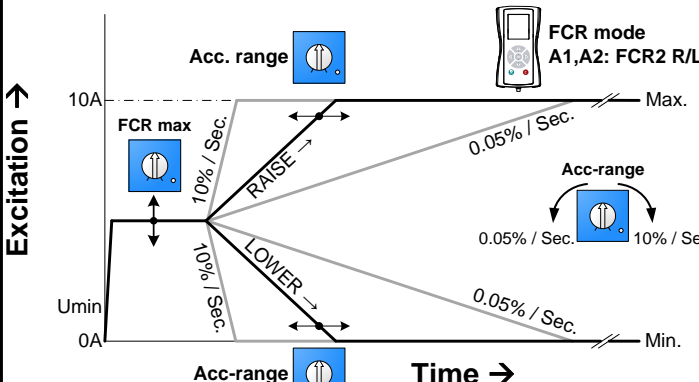

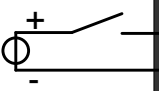
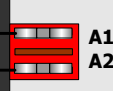
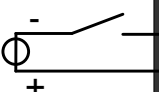
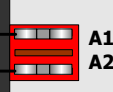





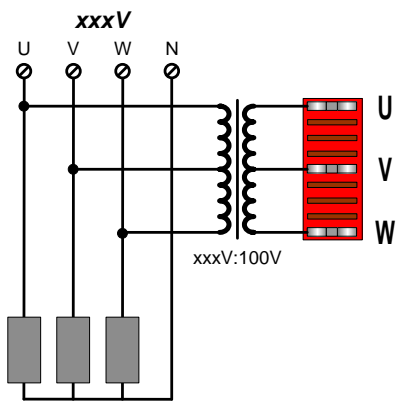

RAISE	12Vdc		
LOWER	12Vdc		

Time →

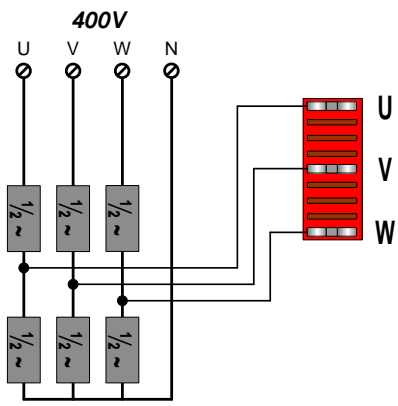
Enable Raise/Lower & FCR2 setpoint with rotary switches (advanced settings III & IV) or set " A1,A2: FCR2 R/L & FCR mode " with AVR Assistant.
The excitation will start from latest setpoint, only when supply has been shutdown (> 10sec) the excitation starts from setpoint FCR max!
During FCR mode, underspeed protection is disabled and there's no generator voltage regulation!

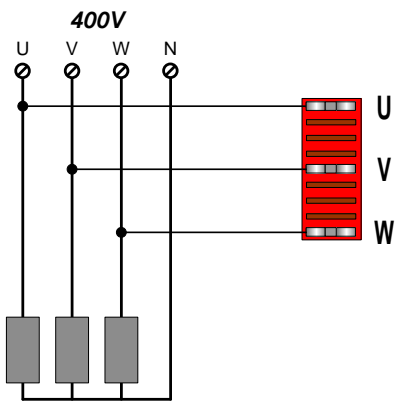
QUICK REFERENCE I

(Page 26..30)

Sensing		
100V Sensing   Dipswitch 1 & 2 off	200V Sensing   Dipswitch 1 on & dipswitch 2 off	400V Sensing   Dipswitch 1 & 2 on
<div style="display: flex; justify-content: space-between;"> Isolated input  <div style="text-align: center;"> <h2>Sensing</h2> <h3>U-V-W clockwise</h3> </div>  </div>		

(Page 9..15)

Accessories input

Max. rating: -13V .. +13V (-26mA..+26mA with Jump R500)

M-Select	Advanced settings
Constant voltage control ----- (-10V .. +10V)	Voltage matching ----- (+6V .. +10V)
Volt per Hertz control ----- (-10V .. +10V)	QPF/kVAR setpoint ----- (-10V .. +10V)
0..100% Voltage control ----- (0V .. +10V)	Raise/Lower control ----- (+12V / -12V)
0..100% Current control ----- (0V .. +10V)	FCR setpoint ----- (0V .. +10V)

Source: D1,D2 (AVR)

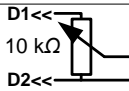

10 kΩ

A1 A2

D1,D2: 10Vdc

Source: -20mA .. +20mA

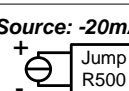

Jump R500

A1 A2

Source: -10V .. +10V

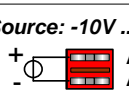

A1 A2

Factory settings		
Parameter	Setpoint	Note
Sensing voltage	400Vac	@ 50Hz
Mode of control	Constant voltage	M-select 0
Underspeed knee	47Hz	M-select 0
Underspeed slope	8V/Hz.	M-select 0
Droop	0V	
I-Limit	Unlimited	I-Limit 9
Prop. gain	50%	
Int. time	50%	
P1	0%	Default : Acc. range
P2	50%	Default : OEL
P3	50%	Default : Cosphi 1
Dip 1	On	Sensing range
Dip 2	On	Sensing range
Dip 3	Off	
Dip 4	Off	
PF1-PF2	Open	Default: QPF mode
TH1-TH2	Linked	Default: 50/60Hz

Link: CAN1-CAN2, TH1-TH2, s-t, AVR1-AVR2, UH1-UH1', WH1-WH1', I1-I1', K1-K1'

(Page 26..30)

Exciter

0 .. 3.5Acd

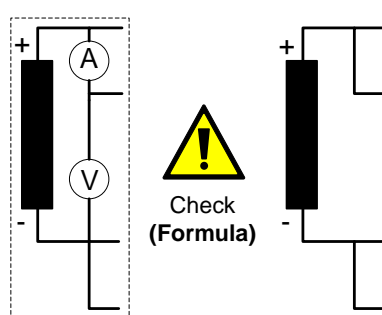

Check (Formula)

Max. rating: Intermittent 15A < 10s.

Formula

Minimum field resistance

$$\text{Field resistance } (\Omega) \geq \frac{\text{Supply input} \times \sqrt{2} (V_{dc})}{20}$$

QUICK REFERENCE I I

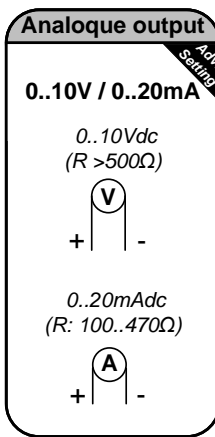
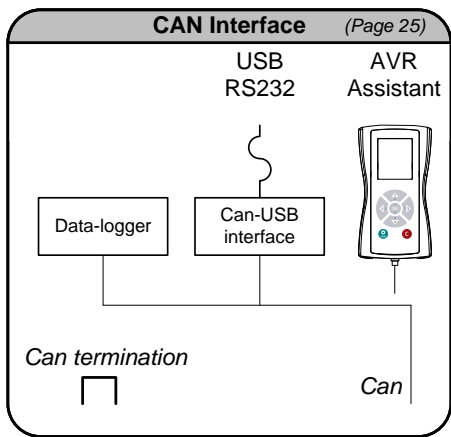

Multipurpose input TH1-TH2 (Page 20,21)

* Check AVR configuration: page 20,21.

TH1-TH2 Configuration	TH1	TH2
(Default) 50/60Hz		(13/14)
Under speed selection (See M-select: page 18)		
KTY		KTY81-110 (1k8..3kΩ)
Temperature sensor		
* QPF2		Jump R121 Isolated source 0..20mA
		Potentiometer 5kΩ
* SR2, UF, ER1, CUN, FCR, kVAr, Reset R/L		(13/14)
Closed = selected mode active		

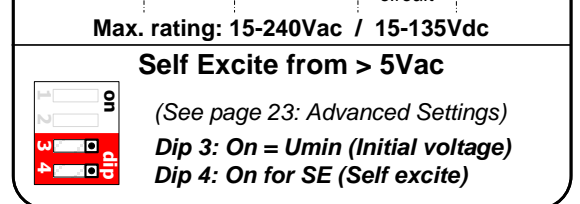
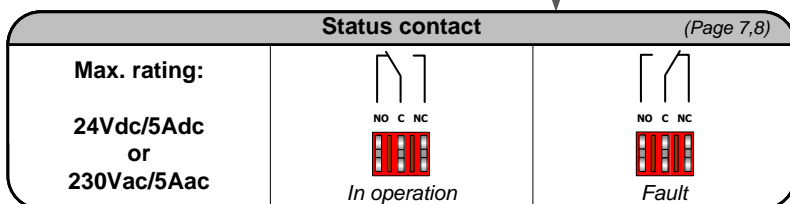
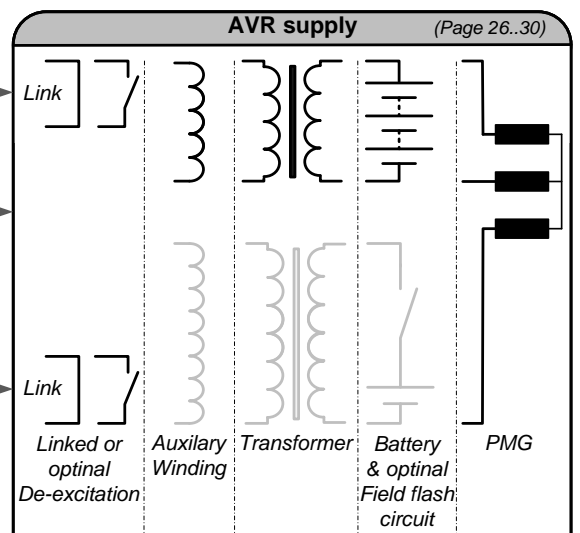
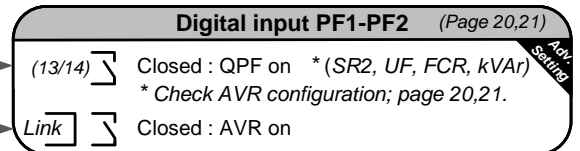
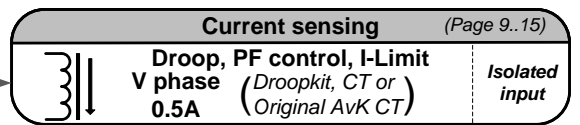
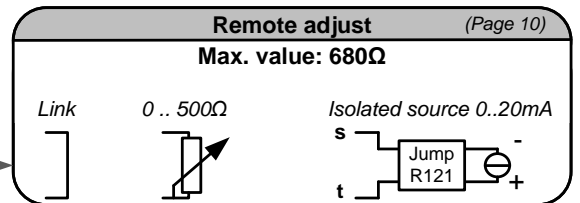
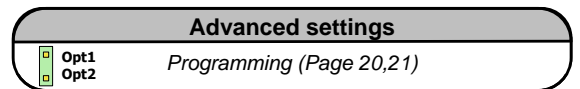
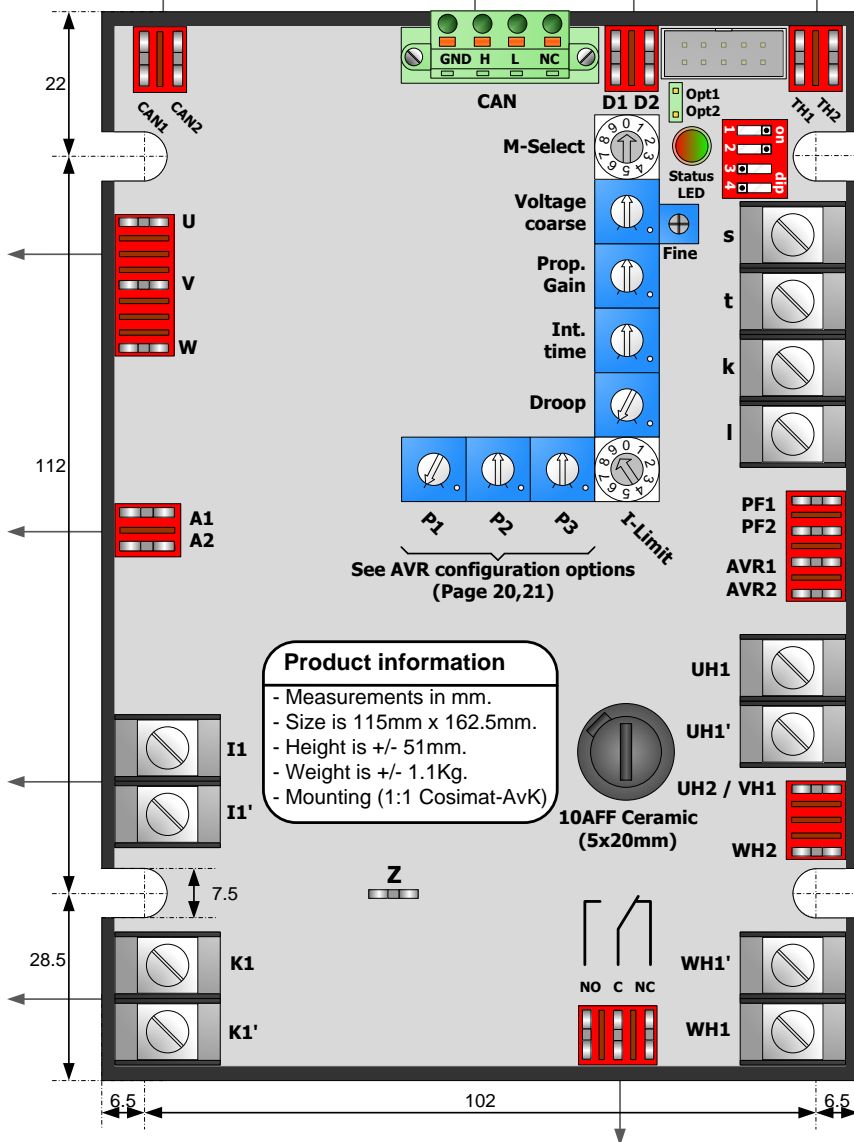



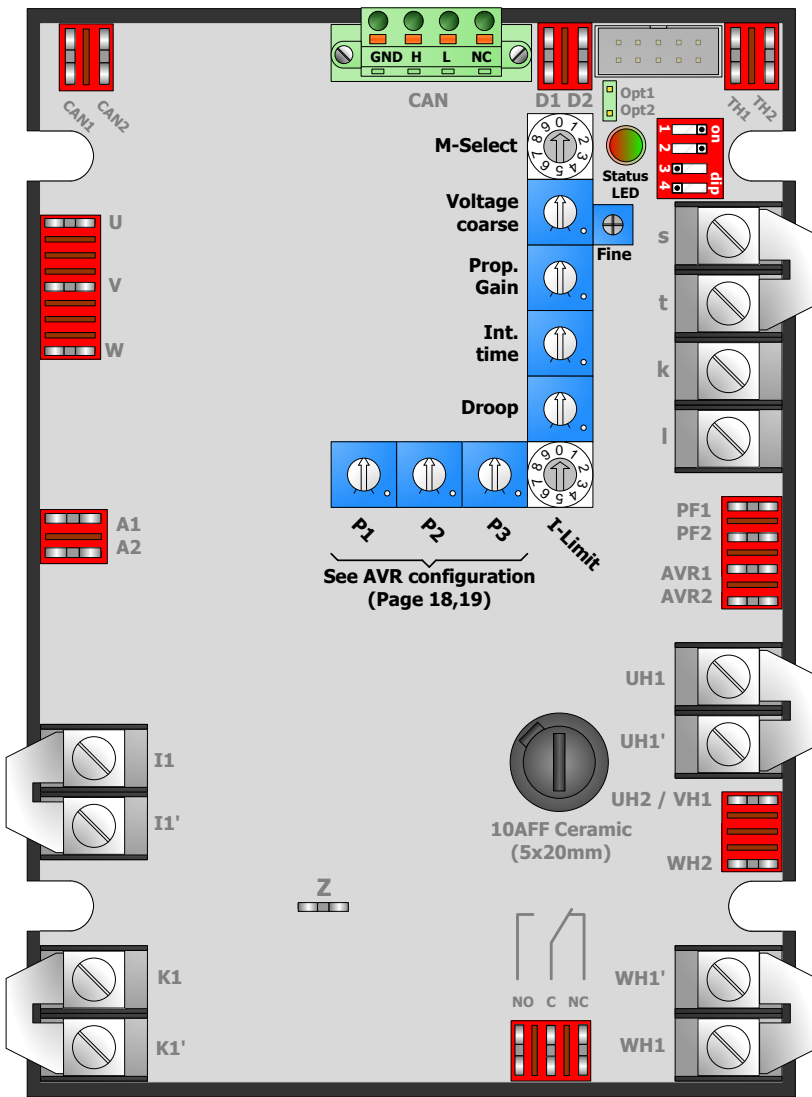





QUICK REFERENCE III



Status LED		
Green Blink		Idle
Orange Blink		Buildup
Green Continuous		Voltage control
Orange Continuous		Current control PF control
Green with Orange blink		VPH control Underspeed (>25Hz)
Red Continuous		Phase sequence Underspeed (<25Hz)
Green with Red blink		Error: (<i>n</i>) number of red blinks
<i>N</i>	<i>Error</i>	
1	Over voltage	
2	Over current	
3	Over excitation	
4	Over temperature AVR	
5	Over temperature generator	
6	Loss of sensing	
7	Loss of excitation during PF control	
8	Loss of current sensing during PF control	
9	Sensing sequence error	
10	100% excitation	

QUICK REFERENCE IV

Voltage (Page 16)

100V	200V	400V
 Dip 1 off & Dip 2 off	 Dip 1 on & Dip 2 off	 Dip 1 on & Dip 2 on
Coarse  88V 132V	Coarse  158V 253V	Coarse  300V 500V
Fine  -1.5% +1.5%	Fine  -1.5% +1.5%	Fine  -1.5% +1.5%

Droop (Page 10)

Droop
 0% 100%
 Droop range : Unom – 10% @ cosphi 0.85 Ind.

Stability (Page 10)



Prop. Gain
 (x Loop gain)



Int. time
 (x Loop gain)

M-Select (Page 9)

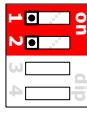
	M-Select (Modes of control) <i>(Page 8..15)</i>	<i>Under speed</i>		
		TH1 – TH2 (50/60Hz)		Slope (400V)
		Linked	Open	
0	Constant voltage control	47 Hz	57Hz	8 V/Hz
1	Constant voltage control	47 Hz	57Hz	16 V/Hz
2	0-100% Voltage control with A1-A2	-	-	-
3	0-100% Current control with A1-A2	47 Hz	57Hz	8 V/Hz
4	Constant voltage control	57 Hz	47Hz	8 V/Hz
5	Constant voltage control	57 Hz	47Hz	16 V/Hz
6	0-100% Voltage control with A1-A2	-	-	-
7	0-100% Current control with A1-A2	57 Hz	47Hz	8 V/Hz
8	VPH (Volt per Hertz) control	-	-	8 V/Hz
9	VPH (Volt per Hertz) control	-	-	8 V/Hz

Dipswitch

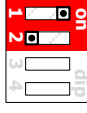

100V Sensing
Dip 1 off & Dip2 off

200V Sensing
Dip 1 on & Dip2 off

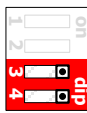
400V Sensing
Dip 1 on & Dip 2 on

Self Excite from > 5Vac
(See page 23: Advanced Settings)
Dip 3: On = Umin (Initial voltage)
Dip 4: On for SE (Self Excite)

I-Limit

 I-Limit (Current limiting)	0 = 60% 5 = 175% 1 = 80% 6 = 200% 2 = 100% 7 = 250% 3 = 125% 8 = 300% 4 = 150% 9 = Unlimited
--	--

ADVANCED SETTINGS II

AVR configuration options				
Digital input PF1-PF2 Program (Page 24,25) Close to activate mode PF1 PF2 (Page 17)	Multipurpose input TH1-TH2 Program (Page 24,25) Close to activate mode TH1 TH2 Sensor KTY81-110 A (Page 17)	Note	Potentiometers P1 P2 P3 (Page 17) (Page 17) (Page 17)	
UF VPH Regulation	KTY Over temperature protection	A	3	Acc. range
	50/60Hz Underspeed knee selection	B	3	Knee Hz
	Reset R/L Reset Raise/Lower setpoint	B	3	Steepness
	UEL Under Excitation Limiting	B	1,4	OEL
	OEL Over Excitation Limiting	B	4	OEL
	OEL+UEL Over and under Excitation Limiting (ER1)	B	1,4	OEL
	CUN Voltage Matching	B	3,5,6	Vbus
	FCR Field Current Regulation	B	2,3,4	FCR max
	kVAr kVAr Regulation	B	3,4	kVAr
	KTY Over temperature protection	A		Acc. range
FCR Field Current Regulation	50/60Hz Underspeed knee selection	B		Acc. range
	Reset R/L Reset Raise/Lower setpoint	B		Acc. range
	UEL Under Excitation Limiting	B	1	Acc. range
	OEL Over Excitation Limiting	B		Acc. range
	OEL+UEL Over and under Excitation Limiting (ER1)	B	1	Acc. range
	CUN Voltage Matching	B	5,6	Vbus
	kVAr kVAr Regulation	B		Acc. range
	KTY Over temperature protection	A		Acc. range
	50/60Hz Underspeed knee selection	B		Acc. range
	Reset R/L Reset Raise/Lower setpoint	B		Acc. range
kVAr kVAr Regulation	UEL Under Excitation Limiting	B	1	Acc. range
	OEL Over Excitation Limiting	B		Acc. range
	OEL+UEL Over and under Excitation Limiting (ER1)	B	1	Acc. range
	CUN Voltage Matching	B	5,6	Vbus
	KTY Over temperature protection	A		Acc. range
	50/60Hz Underspeed knee selection	B		Acc. range
	Reset R/L Reset Raise/Lower setpoint	B		Acc. range
	UEL Under Excitation Limiting	B		Acc. range
	OEL Over Excitation Limiting	B		Acc. range
	OEL+UEL Over and under Excitation Limiting (ER1)	B	1	Acc. range

P1, P2, P3

Acc. range
0% 100%

Knee Hz
30Hz 60Hz

Steepness
3V/Hz 17V/Hz

OEL
1A 13.5A

Vbus
-25% +25%

FCR max
0A 10A

kVAr
0 0.8

1: Only UEL during QPF or kVAr mode. (UEL can be activated and set with AVR Assistant.)
 2: During FCR mode, underspeed protection is disabled and there's no generator voltage regulation!
 4: Acc. range is 0%. (Adjustable with AVR Assistant) 5: Input A1/A2 must be set to "Voltage Match".
 3: OEL is 8A. (Adjustable with AVR Assistant) 6: EMRI LX_VMA or other converter required.

ADVANCED SETTINGS III

Flowchart : Change advanced settings with rotary switches

Begin (Generator stopped !)

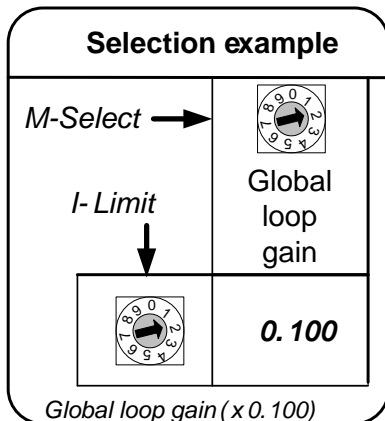
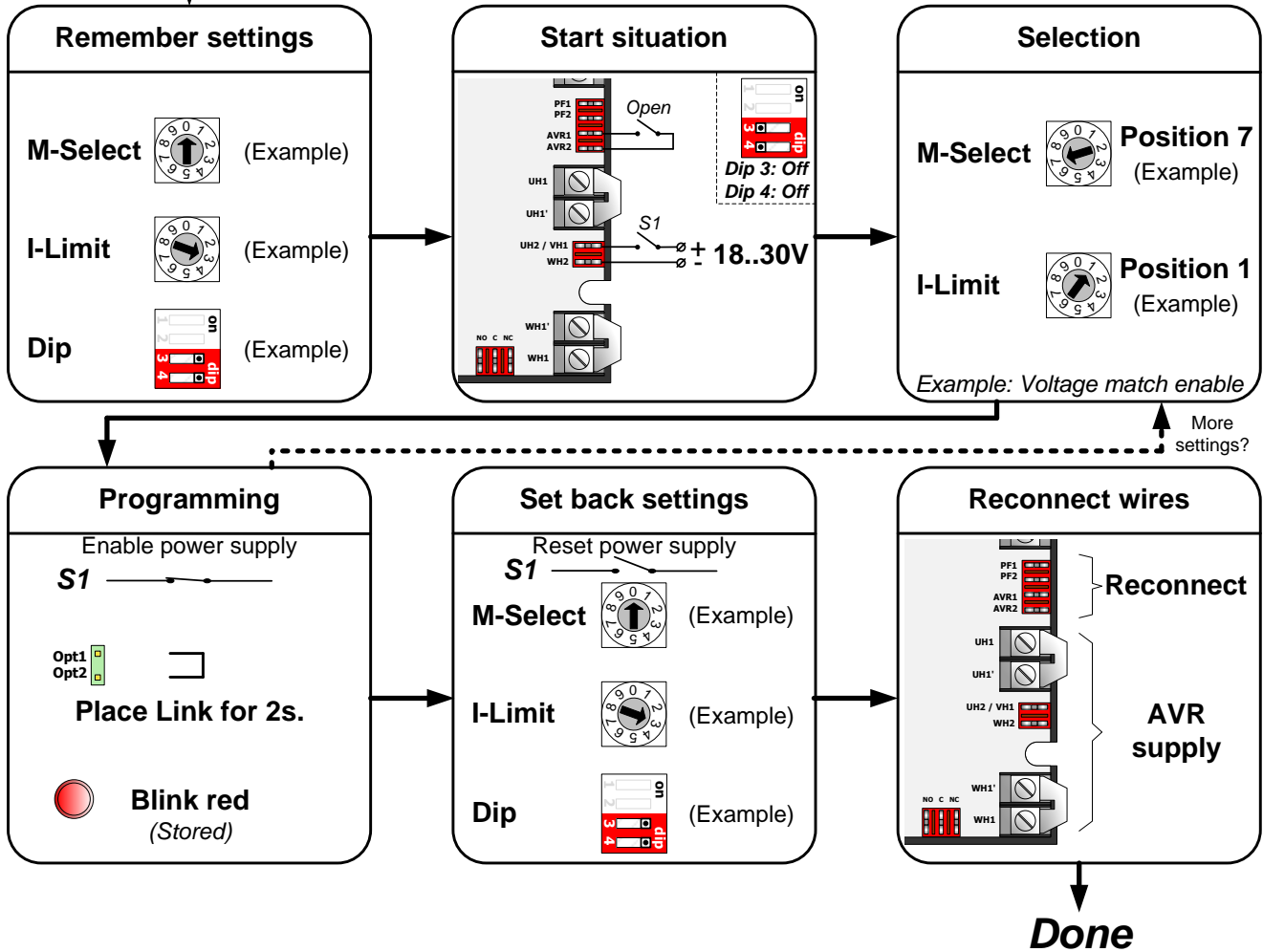



















Note

Change of setting only take effect after restart

Advanced settings can be adjusted according the flowchart.
Advanced settings are available with firmware version 1.0 and higher.

ADVANCED SETTINGS IV

Table: Change advanced settings with rotary switches

M-Select								
	 Buildup gain	 Global loop gain	 Umin (Initial Voltage)	 Protections	 Buildup time (@ startup)	 Option output	 Accessory input modes	 Operation modes
I-Limit								
	0.1 (slowest)	1.000 (fastest)	0%	Excitation loss OFF	1 sec.	Do not use *	Voltage match OFF	Inverted output OFF
	0.2	0.200	7.5%	Excitation loss ON	3 sec.		Voltage match ** ON	Inverted output ON
	0.5	0.100	15%	Phase loss OFF	5 sec.		QPF/kVAR setpoint OFF	SR2 mode OFF
	1	0.066	22.5%	Phase loss ON	7 sec.		QPF/kVAR setpoint ON	SR2 mode ON ****
	2	0.050	30%	Current loss OFF	10 sec.		Raise/lower setpoint OFF	UF mode OFF
	4	0.040	37.5%	Current loss ON	20 sec.		Raise/lower setpoint ON	UF mode ON ****
	6	0.033	45%	Do not use *	30 sec.		FCR1 setpoint OFF	FCR mode OFF
	8	0.028	52.5%	Do not use *	45 sec.		FCR1 setpoint ON	FCR mode ON ****
	10	0.025	60%	Stop after fault OFF	60 sec.		FCR2 setpoint OFF	AFD mode OFF
	14 (fastest)	0.022 (slowest)	67.5%	Stop after fault ON	60 sec.		FCR2 setpoint ON	AFD mode ON ***
Description	Extra multiplication factor for proportional gain. Only applied during field flash.	Extra multiplication factor for proportional gain.	Initial setpoint from which the AVR ramps up after field flash. Setpoint in % of Unom.	Enable or disable the desired protections.	The speed by which the AVR ramps from the minimum setpoint to the nominal setpoint.	Special application	Enable or disable the desired modes of operation.	Enable or disable the desired modes of operation.

* Used only by manufacturer. Contact for more information. ** LX_VMA unit required. *** AFD unit required.

**** SR2, UF or FCR mode selectable at input PF1-PF2. (AVR assistant required to select two modes.)

Default factory settings are highlighted in table. By setting both M-Select and I-Limit at position 9 and placing the programming jumper, will reset the AVR to **default factory settings**.

ADVANCED SETTINGS V

Flowchart : Change advanced settings with AVR Assistant

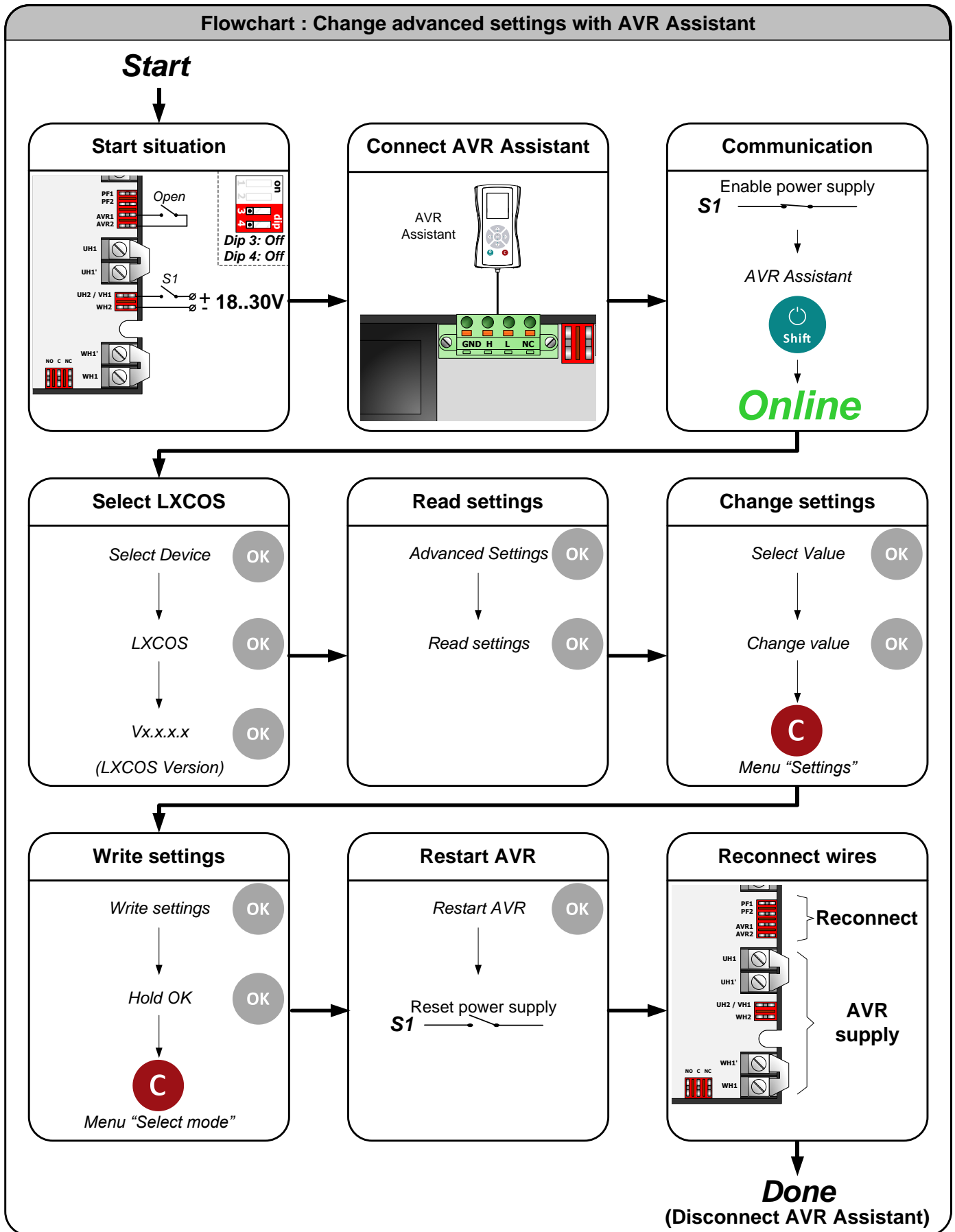

PRIORITY LEVEL

Priority level : Modes of control	
Modes	Priority level
OEL	Highest priority level (OEL)  Lowest priority level (AVR)
UEL	
FCR	
kVAr	
QPF	
SR2	
UF	
CUN	
AVR (M-select : mode of control)	

For more information see "Advanced settings I & II".

CAN INTERFACE

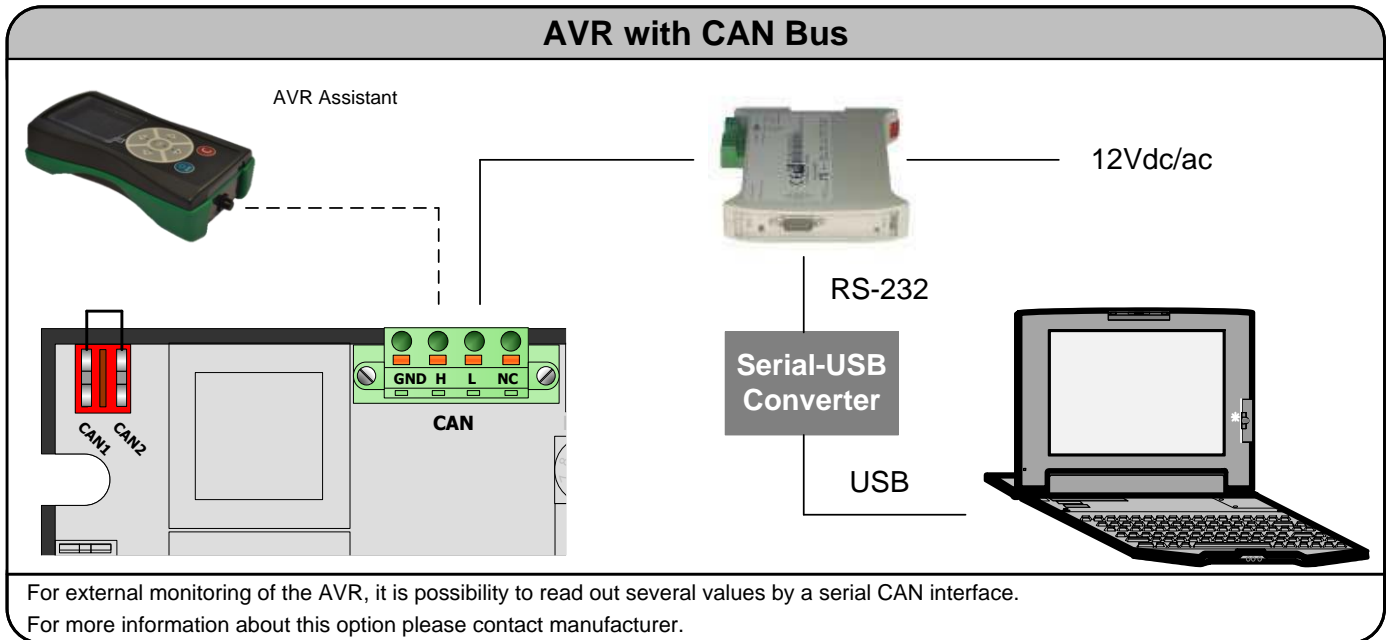

WIRING DIAGRAM I

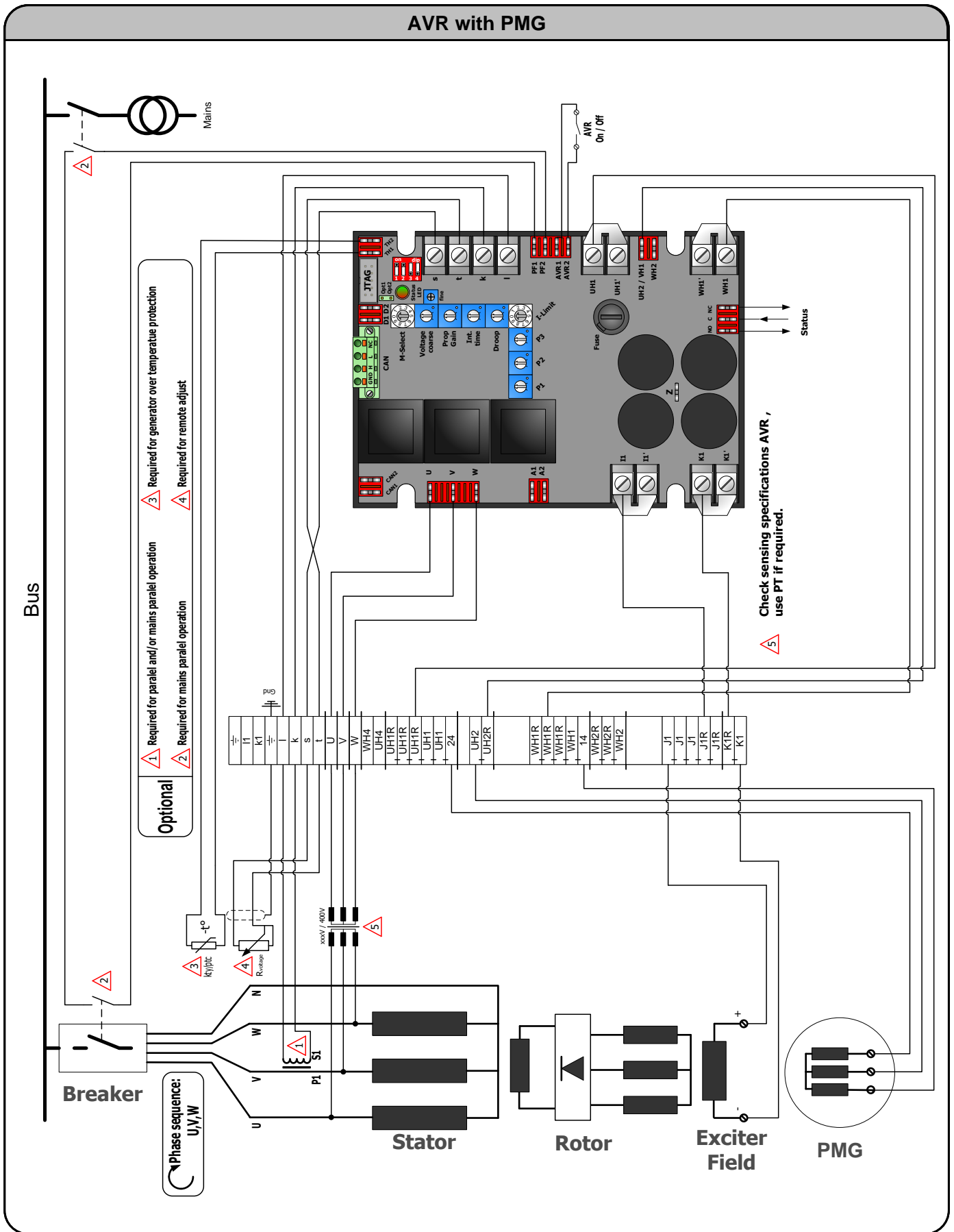

WIRING DIAGRAM III

AVR with transformer (Self excited)

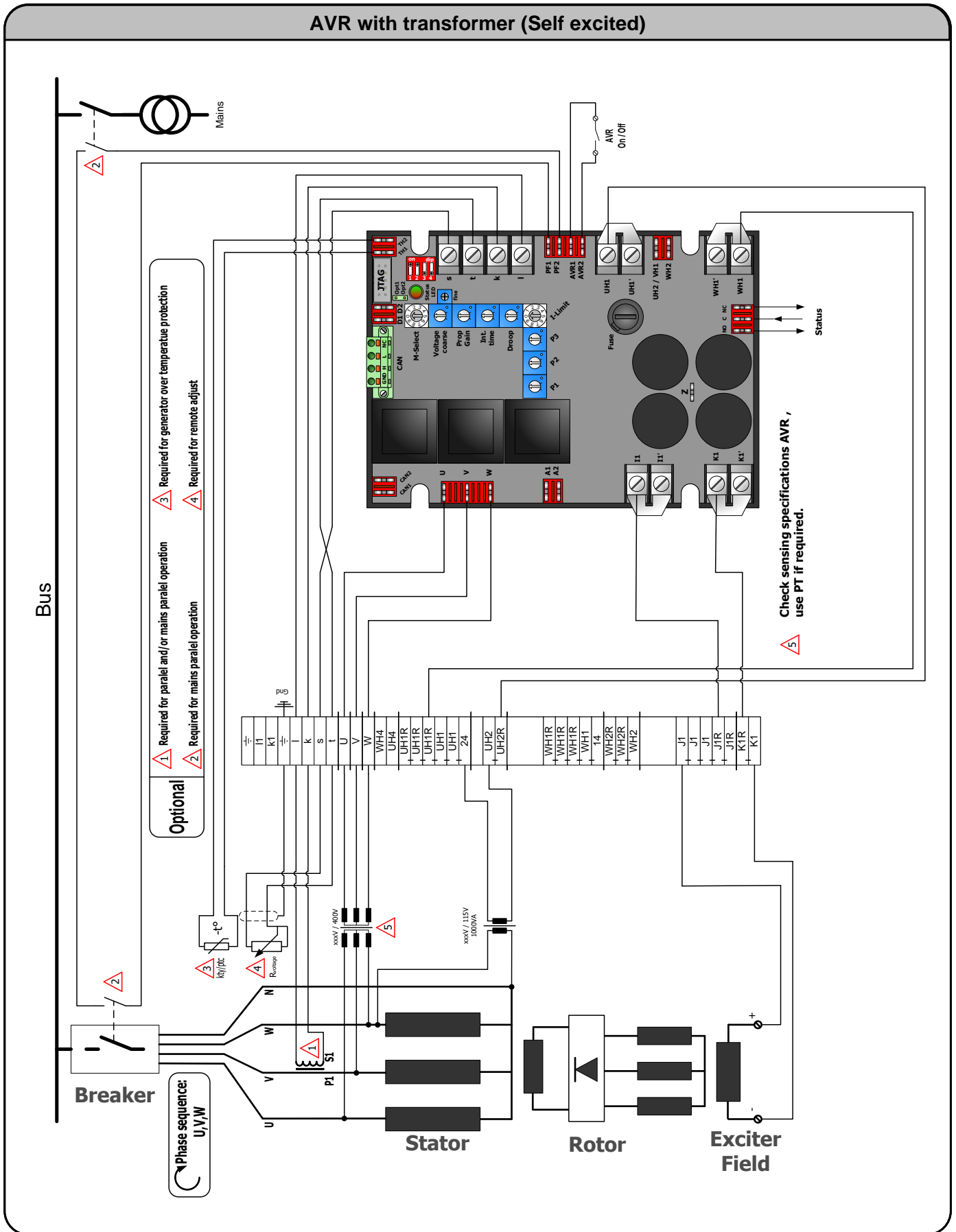

WIRING DIAGRAM IV

AVR inverted operation

Adv. Setting

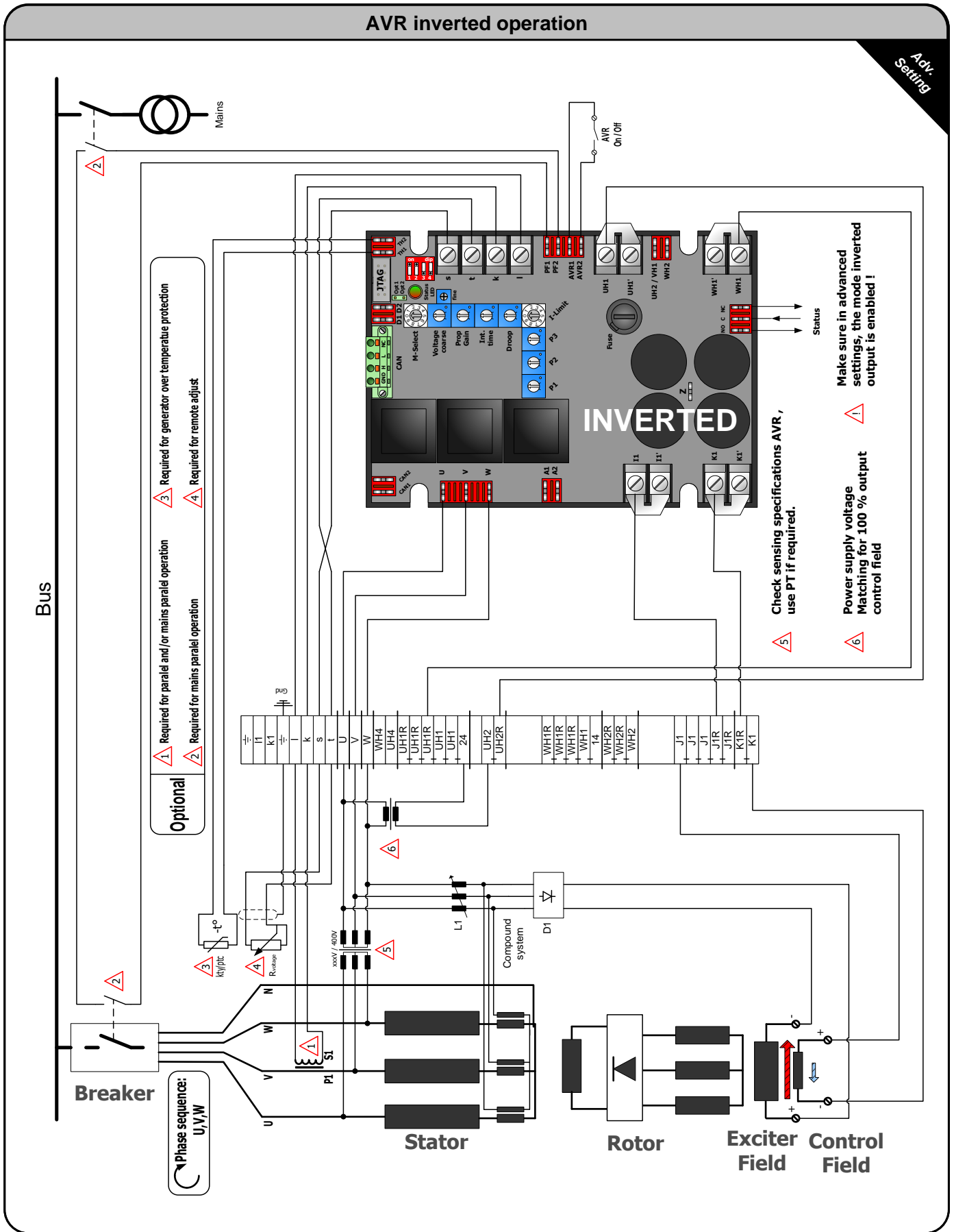

WIRING DIAGRAM V

AVR subtractive operation

Adv. Setting

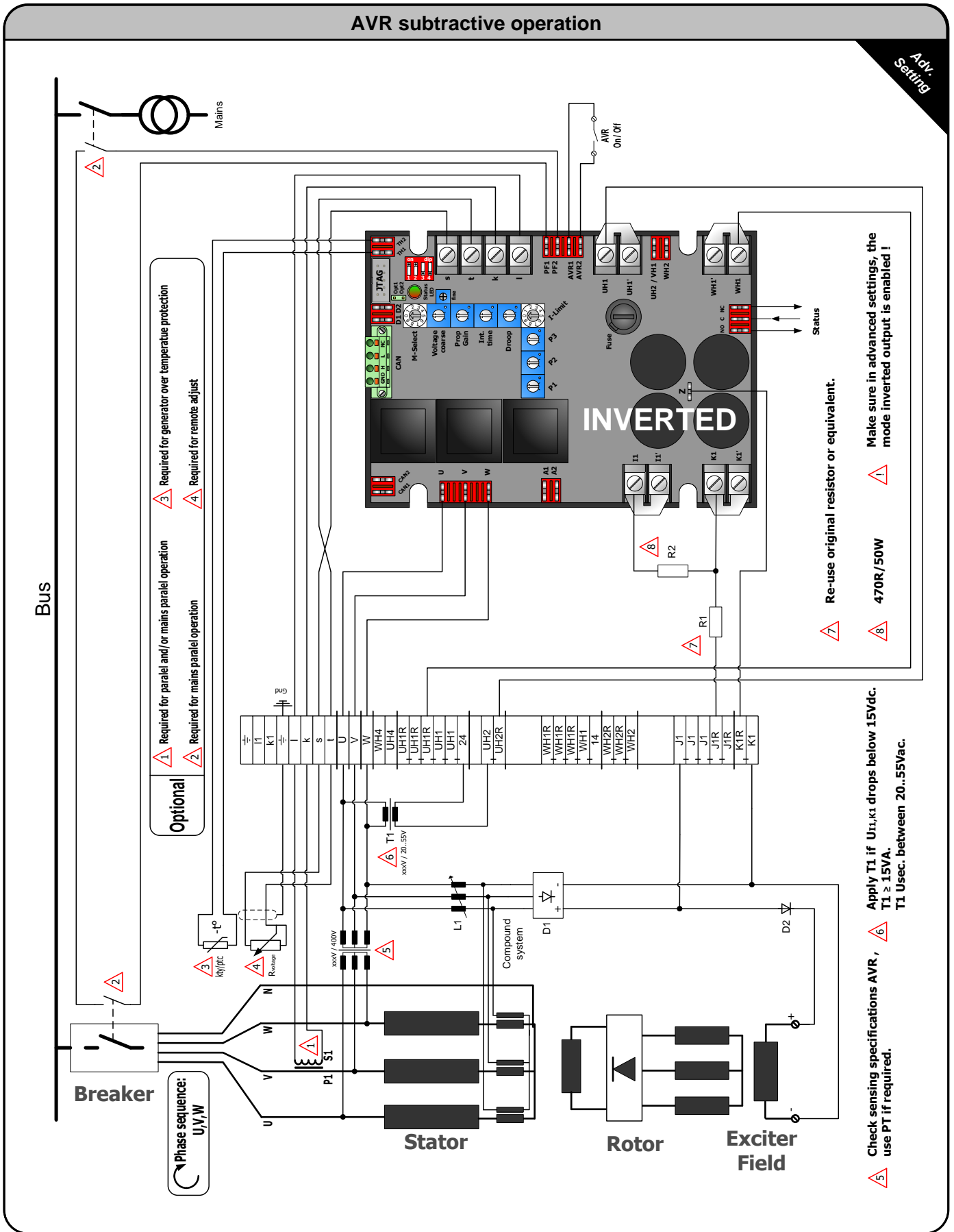

GENERAL INSTALLATION INFORMATION

Absolute Maximum Ratings

- The Absolute Maximum Ratings are those limits for the device that, if exceeded, will likely damage the device. Exceeding the absolute maximum ratings voids any warranty and/or guarantee.

Mounting

Mounting of the product should be done in such a way that:

- the absolute maximum ambient temperature rating of the product will never be exceeded.
- maximum cooling (direction of cooling ribs and direction of airflow) is achieved.
- Mounting no humid air can flow through the product or condensation occurs.
- dust or other materials or residue will not remain in or on the product.
- the maximum vibration is not exceeded.
- personal contact with persons is impossible.

Wiring

- Diameter size of the wiring should be enough to carry the expected current. Wire insulation should be enough to withstand the expected operating voltages and temperatures.
- To improve EMC emission and immunity, care should be taken for the lay out of the wiring. This in respect to all wiring in the installation.
- Keep current carrying wires as short as possible.
- Keep wires carrying a total sum of zero Ampere close to each other, or in one single cable, E.g. U, V, W, or I1 (+) and K1 (-), or Phase and neutral, or s and t.
- Avoid current carrying conductors next to sensing or control wiring. Especially current controlled by SCR's or PWM controlled transistors.
- If sensitive sensing signal cables need to be laid across distance along other cabling, shielded cable is preferred. Keep the shield as long as possible and the wiring outside the shield as short as possible. Do not solder or shrink the shield to a regular wire. Connect the original shield to ground at one side with an as large as possible contact surface.

Additional installation information

- When the product is supplied by means of a transformer, it should never be an auto-transformer. Auto-transformers react as voltage sweep up coil and may cause high voltage peaks.
- Standard fit capacitors or over-voltage suppressers across I1 (+) and K1 (-), or exciter field terminals inside the generator should be removed.
- When the product is supplied by means of a transformer, it should be able to carry at least the maximum expected current. Advisable is, to have a transformer which can carry twice the maximum expected current. Inductive loads make voltage sags and peeks into the secondary voltage of a transformer, from which the device may malfunction.
- It is not recommended to apply switches in dc outputs. It is preferred to use switches in the ac supply inputs of devices. In case it is unavoidable to have switches in the dc output of a device, action must be taken to avoid over voltage damage to the device due to contact arcing. Use a voltage suppressor across the output.
- It is not recommended to apply switches or fuses in the sensing lines. Defects can cause high voltage situations due to over-excitation.
- When using a step down transformer in medium or high voltage generators, the transformer should be three phase (if three phase sensing), and the transformer should be suitable for acting as a sensing transformer. If the transformer is unloaded, connect a resistor to avoid voltage waveform distortion.
- The phase relation from the generator to the AVR is important. Also when voltage transformers and/ or current transformers are installed.
- When using a step down or insulation transformer in the droop circuit, phase relation from the generator to the AVR is important.
- CT's wiring, connected to the AVR should never be grounded.
- Always disconnect electronic products, circuits and people before checking the insulation resistance (Megger check).
- Due to differences in generators impedance's, EMC behavior is not predictable. Therefore the commissioner / installer should be aware of proper and correct installation.
- Large, highly inductive, exciter stator windings can cause destructive high voltage peaks. Adding a resistor from 10 to 20 times the exciter stator field resistance reduces voltage spikes. If necessary filter can be fitted additionally. (e.g. snubber, RC-network)
- Upon problems during commissioning, faulty behavior or defects in the generator, consult the fault finding manual at our web site
- Some advises may be overdone or seem extraordinary, but since the electrical rules are the same everywhere, these advises are given.

CONTACT

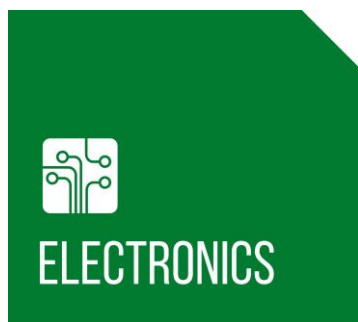

EMRI Electronics B.V.
Morsestraat 10
6716 AH, Ede, Netherlands
Tel: +31 (0)318 620 427
Website: www.emri.nl
E-mail: info@emri.nl

Manufacturer



CANARY ISLANDS, Las Palmas
Zamakona Yards
Tel: +34 928467521
Fax: +34 928461233
Website: www.zamakonayards.com/
E-mail: ibetancor@zamakonayards.com

CHILE, Santiago
Lucio Vicencio y CIA.LTDA
Tel: +1-281-334-2904
Fax: +1-832-221-5642
Website: www.luciovicencio.cl
E-mail: luciovincencioltda@gmail.com

GREECE, Piraeus
Stavros Kassidiaris S.A.
Tel: +30 210 4636000
Fax: +30 210 4624471
Website: www.kassidiaris.gr
E-mail: info@kassidiaris.gr

ICELAND, Hafnarfjordur
Rafeining ehf
Tel: +354 565 3049
Fax: +354 565 3048
Website: www.rafeining.is
E-mail: rafeining@rafeining.is

INDIA, Faridabad
Power Solutions
Tel: +91 9868907903
Fax: +91 129 2431216
Website: www.psolindia.com
E-mail: ramesh.powersolutions@gmail.com

NORWAY, Bergen
Frydenbø Electric A/S
Tel: +47 55 34 91 00
Fax: +47 55 34 91 10
Website: www.frydenbo.no
E-mail: firma.fel@frydenboe.no

POLAND, Gdynia
An-Elec Sp. z o.o.
Tel: +48 58 668 44 00
Fax: +48 58 668 44 66
Website: <http://an-elec.pl>
E-mail: info@an-elec.pl

POLAND, Szczecin
MARCONTREL
Tel: +48 91 4 888 474
Fax: +48 91 4 888 475
Website: www.marcontrel.com
E-mail: emri@marcontrel.com

POLAND, Szczecin-Mierzyn
Marel Serwis
Tel: +48 91 48 58 388
Fax: +48 91 48 79 948
Website: www.marel.szczecin.pl
E-mail: handel@marel.szczecin.pl

REPUBLIC OF PANAMA, Panama
PASRAS S.A.
Tel: +507 3140095
Fax: +507 3140094
Website: www.pasras.com
E-mail: info@pasras.com

ROMANIA, Constanta
SAMTEC SRL
Tel: +40 241 517 047
Fax: +40 241 517 047
Website: www.samtec.ro
E-mail: samtec_srl@yahoo.com

SINGAPORE, Singapore
Cyclelect Electrical Engineering
Tel: +65 6868 6013
Fax: +65 6863 6260
Website: www.cyclelect.com.sg
E-mail: heng.p@cyclelect.com.sg

SOUTH AFRICA, Roodepoort
Yneldo Electronics
Tel: +27(0)117637053
Fax: +27(0)117634212
Website: www.yneldo.com
E-mail: yneldo@yneldo.com

SWEDEN, Kungälv
Elektrisk Drivteknik EDT AB
Tel: +46-705-28 20 60
Tel: +46-709-50 47 90
Website: www.edtab.se
E-mail: info@edtab.se

THAILAND, Bang Lamung
Semtec Maritime/Genetech Co.Ltd
Tel: +66 38301262
Fax: +1-832-221-5642
Website: semtecmaritime.com/
Email: ron@northstarusa.co

TURKEY, Izmir
INTEGRAL
Tel: +90 (555) 211 55 75
Email: ozgur@integralguc.com

UNITED ARAB EMIRATES, Sharjah
KDU Technical Services
Tel: +971-6-5575480
Fax: +971-6-5575490
Website: www.kdutech.ae
E-mail: kdutech@kdutech.ae

UNITED KINGDOM, Stockton on Tees
MJR Controls
Tel: +44 1642 762 151
Fax: +44 1642 762 502
Website: www.mjrcontrols.com
Email: chris.milner@mjrcontrols.com

UNITED KINGDOM, Cheadle Hulme
TGS Total Generator Solutions Ltd
Tel: +44161 8188720
Fax: +447754677963
Website: <http://totalgeneratorsolutions.com>
Email: sales@totalgeneratorsolutions.com

UNITED STATES, Kemah - Texas
Ramtec Marine Systems LLC
Tel: +1-281-334-2904
Fax: +1-832-221-5642
Website: www.ramtec-marine.com
Email: waling@ramtec-marine.com